



V-Pro™ Hopper Spreader

Spreaders for Snow & Ice Control

FOR MODELS

Vee Pro 3000
Vee Pro 6000

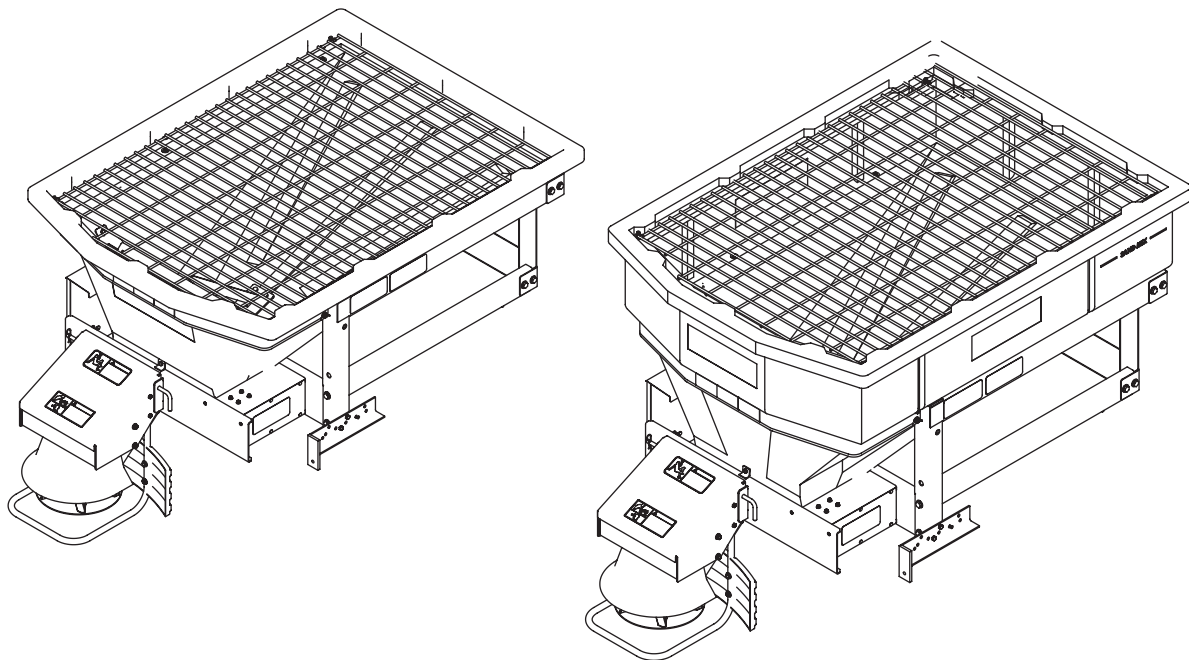

Introduction	3
General Information and Registration	4
Safety Information	5-7
Spreader Assembly and Exploded Views.....	8-16
Wiring Instructions	17
Electrical System Information.....	18-24
Spreader Mounting and Assembly Views	25-26
Vee Pro Express Kit.....	27-28
Vibrator Kit.....	29-30
Adjustable Baffle Kit.....	31
Spreader Operating Information	32-33
Troubleshooting Information.....	34-36
Spreader Maintenance	37
Determine Vehicle Payload Chart	38
Blank Pages	39-41
Warranty Declaration	42
Warranty Registration.....	43

Have a question or need assistance?
SnowEx Customer Service
(800) 725-8377

or (586) 756-6555

Monday through Friday 8:00 AM to 4:30 PM EST

Fax: (586) 427-0552

E-Mail: customercare@trynexfactory.com

Website: www.snowexproducts.com

This manual has been designed for your help. It will assist you and instruct you on the proper set-up, installation and use of this spreader.

Refer to the table of contents for an outline of this manual.

We require that you read and understand the contents of this manual completely (especially all safety information) before attempting any procedure contained herein.



THIS SIGN SHOULD ALERT YOU:

The Society of Automotive Engineers has adopted this SAFETY ALERT SYMBOL to pinpoint characteristics that, if NOT carefully followed, can create a safety hazard. When you see this symbol in this manual or on the machine itself, BE ALERT! Your personal safety and the safety of others is involved.

Defined below are the SAFETY ALERT messages and how they will appear in this manual:



DANGER

(RED)

Information that, if not carefully followed, can cause death!



WARNING

(ORANGE)

Information that, if not carefully followed, can cause serious personal injury or death!



CAUTION

(YELLOW)

Information that, if not carefully followed, can cause minor injury or damage to equipment.

CONGRATULATIONS!

The spreader you have purchased is an example of snow and ice control technology at its finest! Your spreader's self-contained design is a trademark of all Snowex products. Here's why...

SIMPLICITY: Fewer moving parts manufactured of higher quality means minimal maintenance for your SnowEx spreader.

RELIABILITY: High impact linear low density polyethylene hopper, state-of-the-art electronic dual variable speed control, custom engineered powder coated frame, maximum torque 12 volt motor coupled to a custom engineered transmission; found only on SnowEx products.

VERSATILITY: Multi-use capabilities allows spreading of a variety of materials for snow and ice control.

WARRANTY: Best in the industry, hands down! 2 years standard and now 5 year extended (optional).

The benefits you are about to recognize are that of time, money and effort. We welcome you to the world of Snowex Performance.

Registration

Record the following information in this manual for quick reference.

Spreader Model Number _____

Spreader Serial Number _____ Controller Serial Number _____

Date of Purchase _____

Dealer Where Purchased _____

When ordering parts, the above information is necessary. This will help to that you receive the correct parts.

At the right is a diagram of the ID tag. This tag on the spreader is located on the frame.



Please fill out the warranty card with all the necessary information to validate it. This will also give us a record so that any safety or service information can be communicated to you.



Before attempting any procedure in this book, these safety instructions must be read and understood by all workers who have any part in the preparation or use of this equipment.

For your safety, warning and information decals have been placed on this product to remind the operator of safety precautions. If anything happens to mark or destroy the decals, please request new ones from Snowex.



Unit must be pinned and locked into position before operating vehicle.



Never exceed the Gross Vehicle Weight Rating of vehicle. Failure to do so may limit a vehicle's handling characteristics.



Never attempt to take a unit off a truck with material in it.



Never exceed 45 m.p.h. when loaded spreader is attached to vehicle. Braking distances may be increased and handling characteristics may be impaired at speeds above 45 m.p.h.



Never allow children to operate or climb on equipment.
Always check areas to be spread to be sure no hazardous conditions or substances are in the area.
Always inspect unit for defects: broken, worn or bent parts, weakened areas on spreader or mount.



Always shut off vehicle and power source before attempting to attach or detach or service spreader unit. Be sure vehicle/power source is properly braked or chocked.



Always keep hands, feet, and clothing away from power-driven parts. Remember it is the owner's responsibility to communicate information on safe usage and proper maintenance of all equipment.



Always make sure personnel are clear of areas of danger when using equipment. Maintain 60' distance from all bystanders when operating the spreader.





Inspect the unit periodically for defects. Parts that are broken, missing, or worn out must be replaced immediately. The unit, or any part of it can not be altered without prior written permission from the manufacturer.





Never use with foreign debris in the spreader. These units are designed to handle clean, free-flowing material.

 **WARNING** Always inspect pins and latches whenever attaching or detaching spreader, and before traveling.

 **CAUTION** Never leave material in hopper for long periods of time. Be aware that all ice melters are hygroscopic and will attract atmospheric moisture and harden up.

 **WARNING** Remember, most accidents are preventable and caused by human error. Exercising of care and precautions must be observed to prevent the possibility of injury to operator or others!

 **WARNING** Never operate equipment when under the influence of alcohol, drugs, or medication that might alter your judgment and/or reaction time.

 **WARNING** Before working with the spreader, secure all loose fitting clothing and unrestrained hair.

 **WARNING** Always wear safety glasses with side shields when servicing spreader. Failure to do this could result in serious injury to the eyes.

Safety and Warning Labels

Model # SP-3000/SP-6000

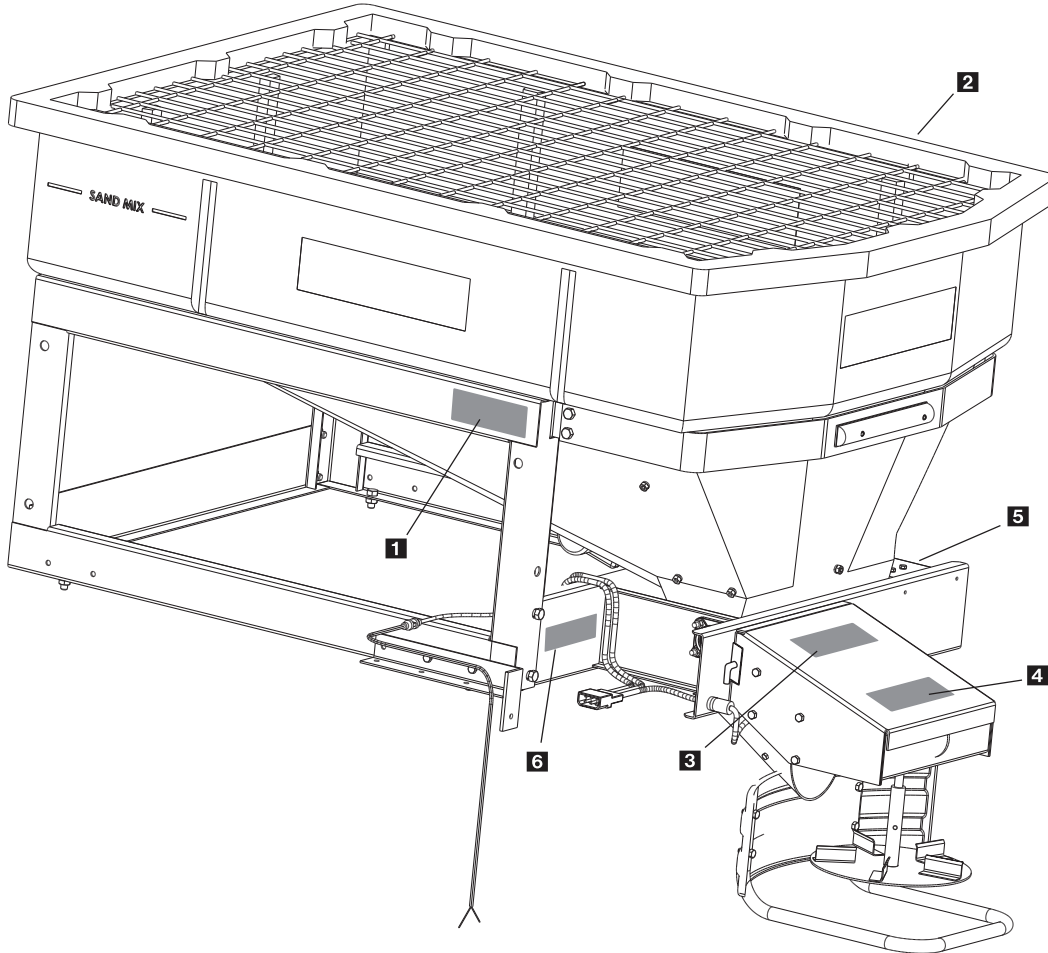

1 D 6546



2 D 6547



3 D 6545



4 D 6544



5 D 6335



6 D 6548

Side and Bottom View
Model # SP-3000

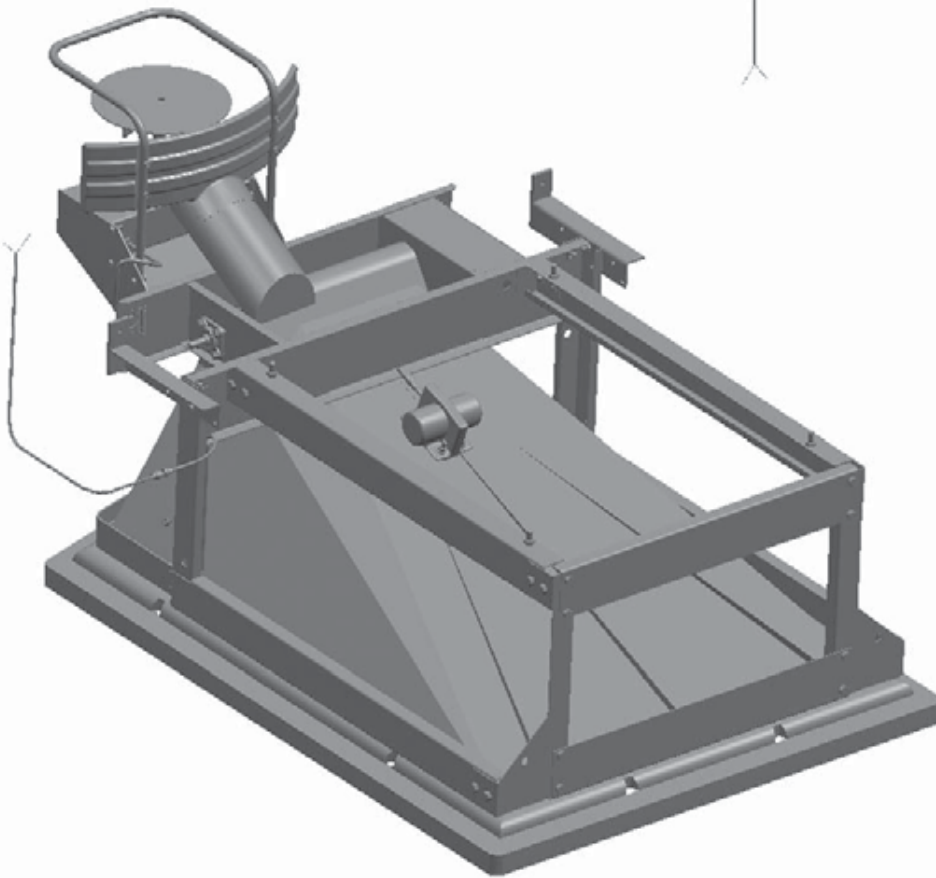
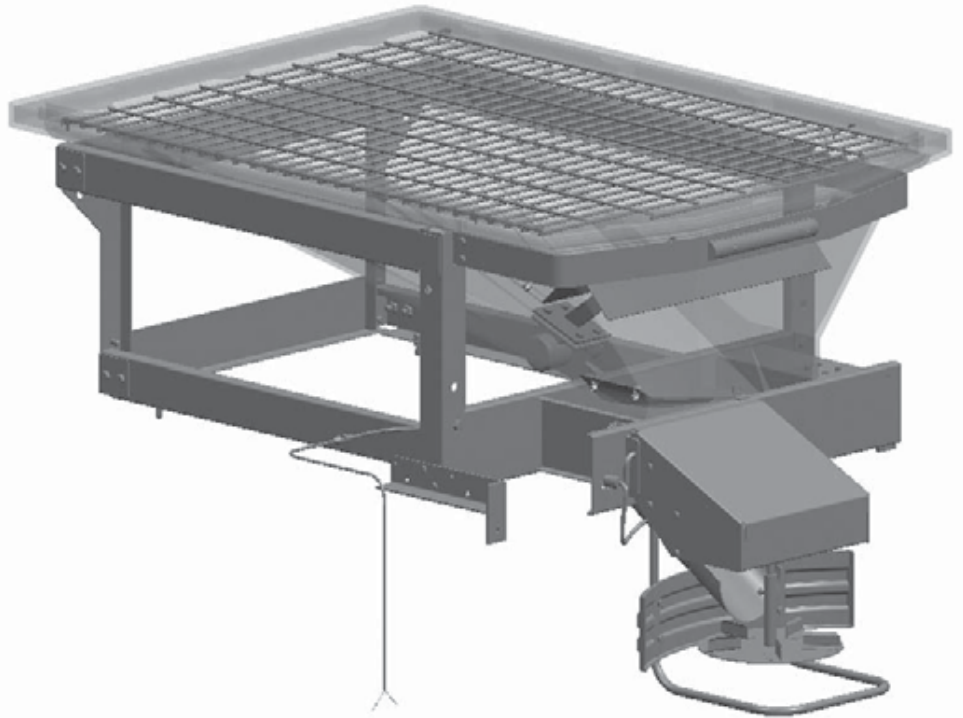

Side and Bottom View
Model # SP-6000

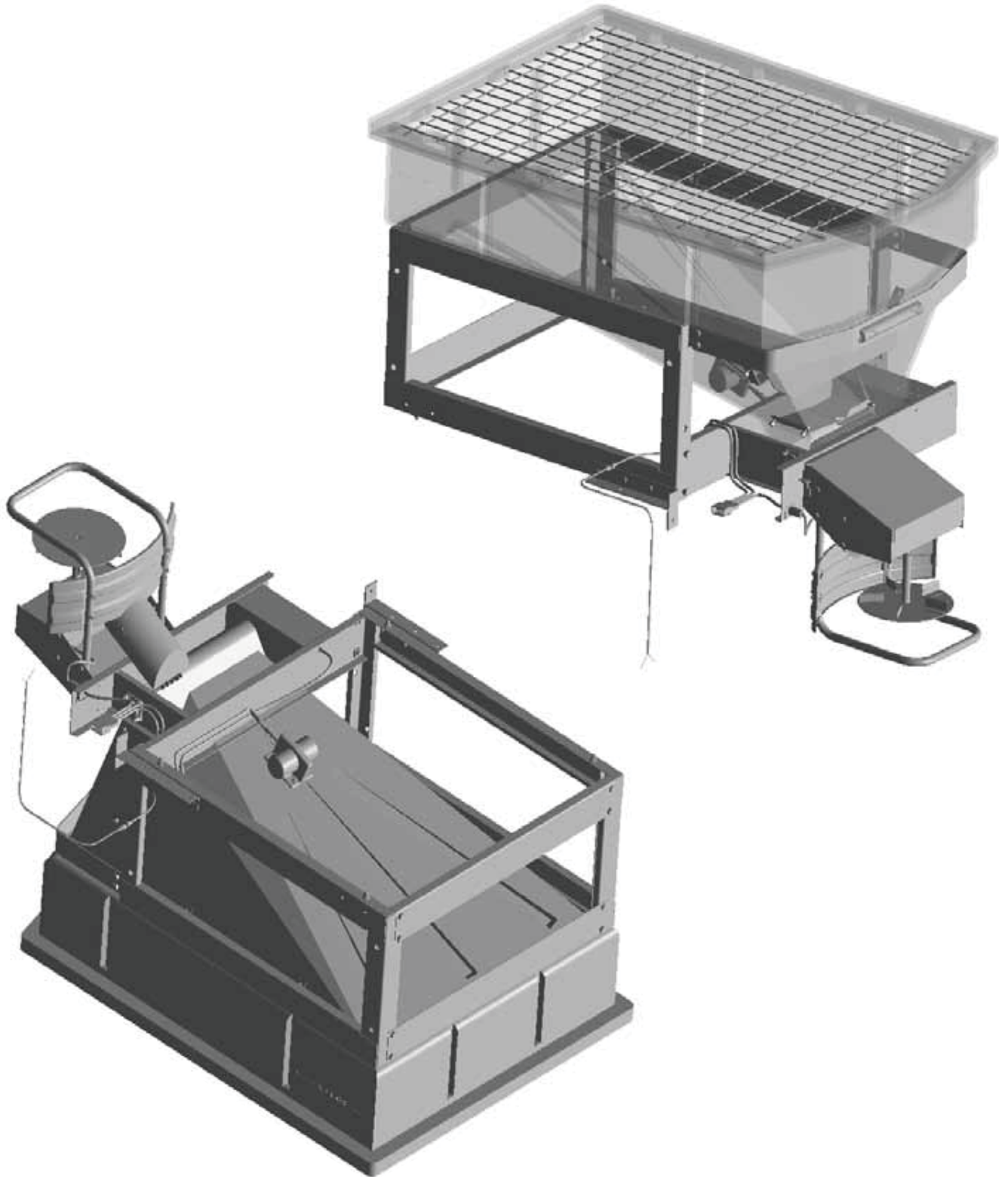

Auger Drive Assembly Parts Breakdown

Model # SP-3000/SP-6000

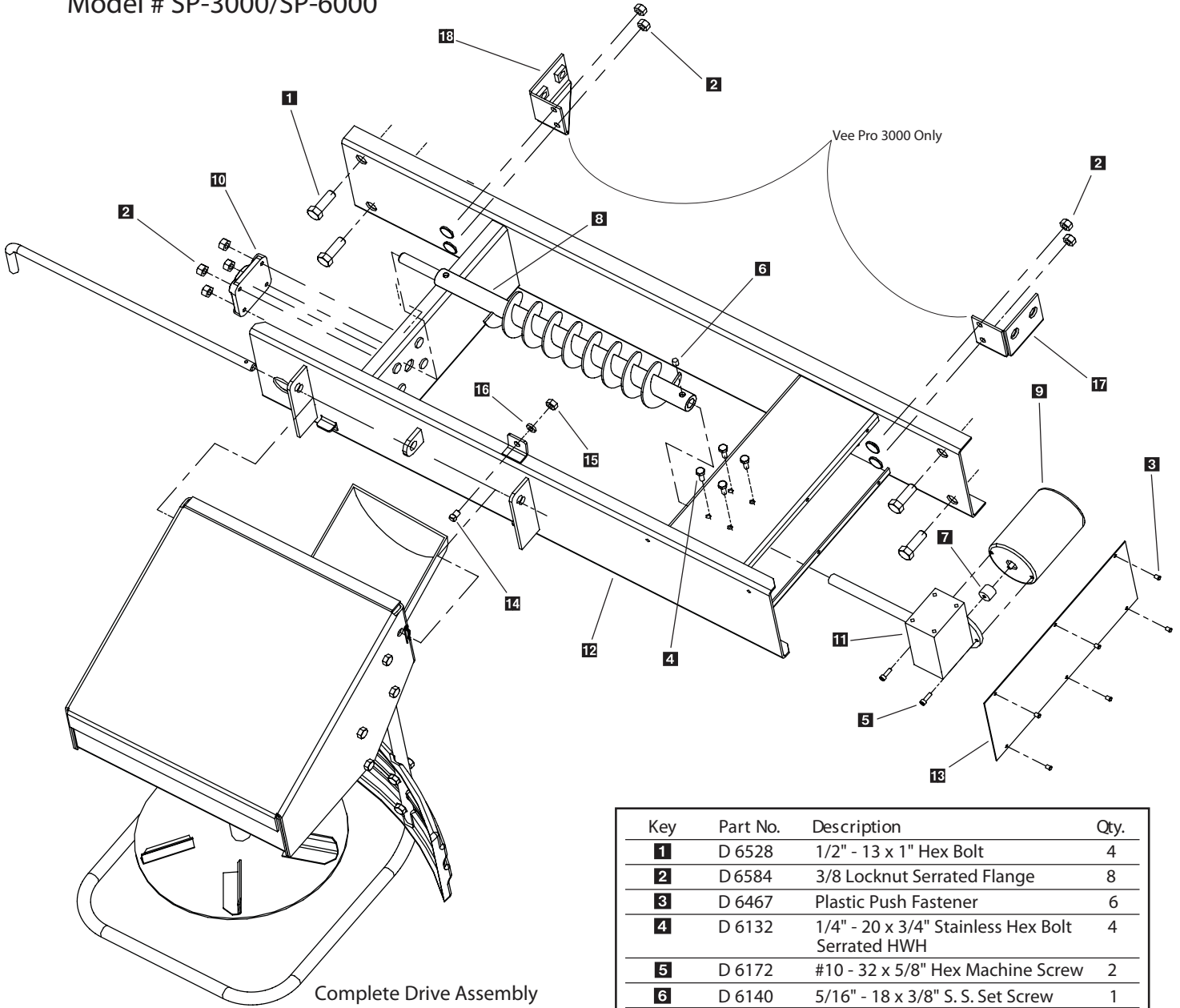

Complete Drive Assembly
D6565

Key	Part No.	Description	Qty.
1	D 6528	1/2" - 13 x 1" Hex Bolt	4
2	D 6584	3/8 Locknut Serrated Flange	8
3	D 6467	Plastic Push Fastener	6
4	D 6132	1/4" - 20 x 3/4" Stainless Hex Bolt Serrated HWH	4
5	D 6172	#10 - 32 x 5/8" Hex Machine Screw	2
6	D 6140	5/16" - 18 x 3/8" S. S. Set Screw	1
7	D 6232	Motor Drive Coupler	1
8	D 6562	20" Auger	1
9	D 6320	Auger Motor	1
10	D 6512	Bearing with Cover	1
11	D 6566	Auger Trans/30:1	1
12	D 6534	VP Auger Drive Weld Assy.	1
13	D 6535	Auger Motor Cover	1
14	D 6524	5/16" - 18 x 1-1/2" Tap Bolt	1
15	D 6138	5/16" Lock Nut	1
16	D 6165	5/16" Flat Washer	1
17	D 6736	3000 Mounting Bracket - Right	1
18	D 6737	3000 Mounting Bracket - Left	1

Main Assembly Parts Breakdown

Model # SP-3000

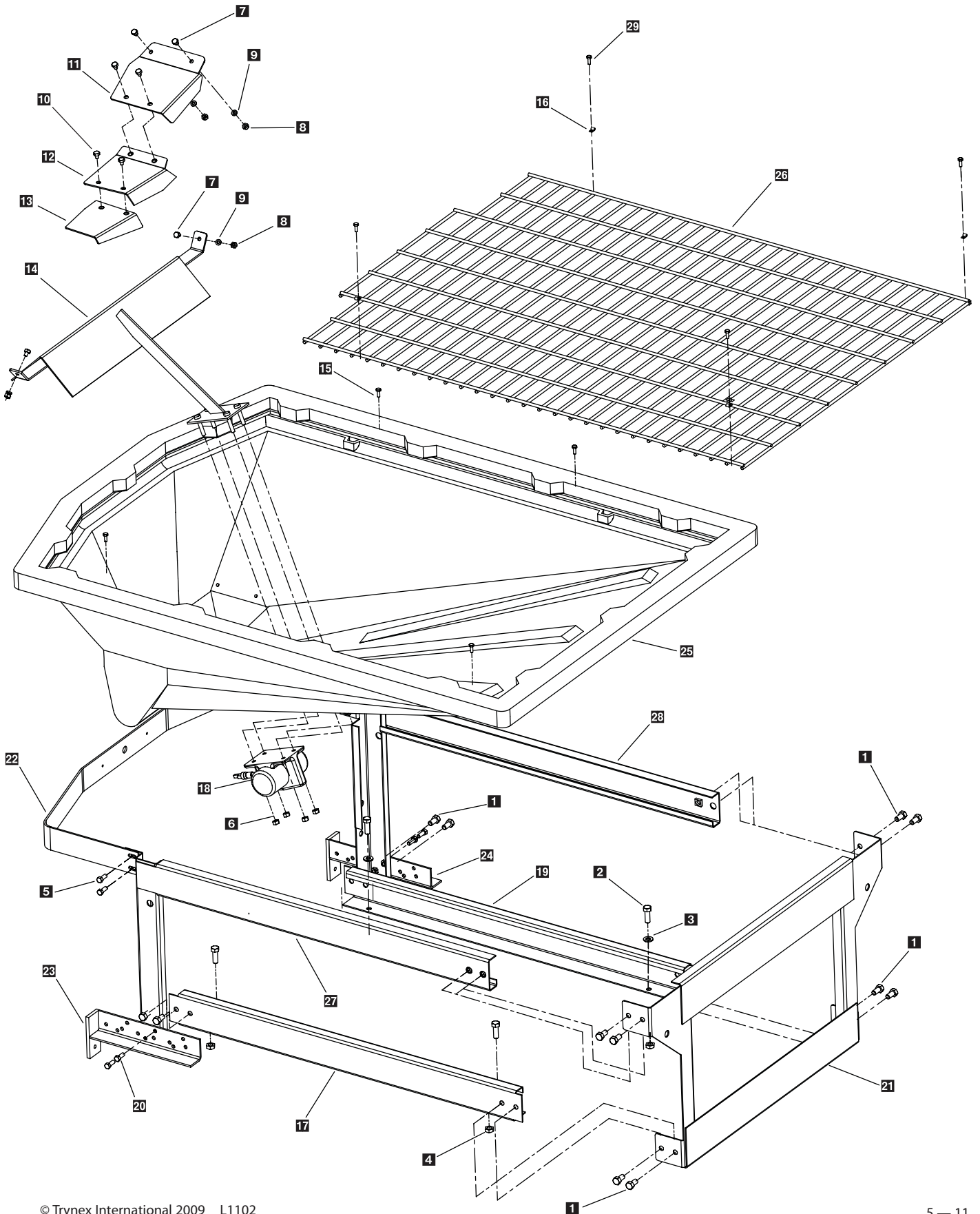

Main Assembly Parts Breakdown

Model # SP-3000



Key	Part No.	Description	Qty.
1	D 6528	1/2" - 13 x 1" Hex Bolt Serrated Head	12
2	D 4116	1/2" - 13 x 1-1/2" Hex Bolt	4
3	D 4119	1/2" Flat Washer	4
4	D 4120	1/2" Lock Nut	4
5	D 6452	3/8" - 16 x 1" Hex Bolt Serrated HWH Type F	4
6	D 6584	3/8" Serrated Lock Nut	4
7	D 6524	5/16" - 18 x 1-1/2" Tap Bolt	4
8	D 6138	5/16" Hex Nut	4
9	D 6165	5/16" Lock Washer	4
10	D 6452	3/8-16 x 1 Serrated Flange	4
11	D 6471	Main Baffle	1
12	D 6472	Second Baffle	1
13	D 6473	Third Baffle	1
14	D 6504	Inverted Vee	1
15	D 6874	#14 x 1-1/4" SS Self Drilling Hex Head TEK Screw	4
16	D 6509	Top Screen Hold Down	4
17	D 6496	Lower Rail Right	1
18	D 6515	Heavy Duty Vibrator	1
19	D 6497	Lower Rail Left	1
20	D 4121	3/8" - 16 x 1" Hex Bolt	4
21	D 6738	Front Frame Weldment	1
22	D 6533	Hopper Apron	1
23	D 6536	Adj. Stop Bracket RT	1
24	D 6537	Adj. Stop Bracket LT	1
25	D 6585	3000 Vee Hopper	1
26	D 6506	3000/6000 Top Screen	1
27	D 6490	3000 Right Frame Weldment	1
28	D 6491	3000 Left Frame Weldment	1
29	D 6553	Top Screen Hold Down Screw	4

Main Assembly Parts Breakdown

Model # SP-6000

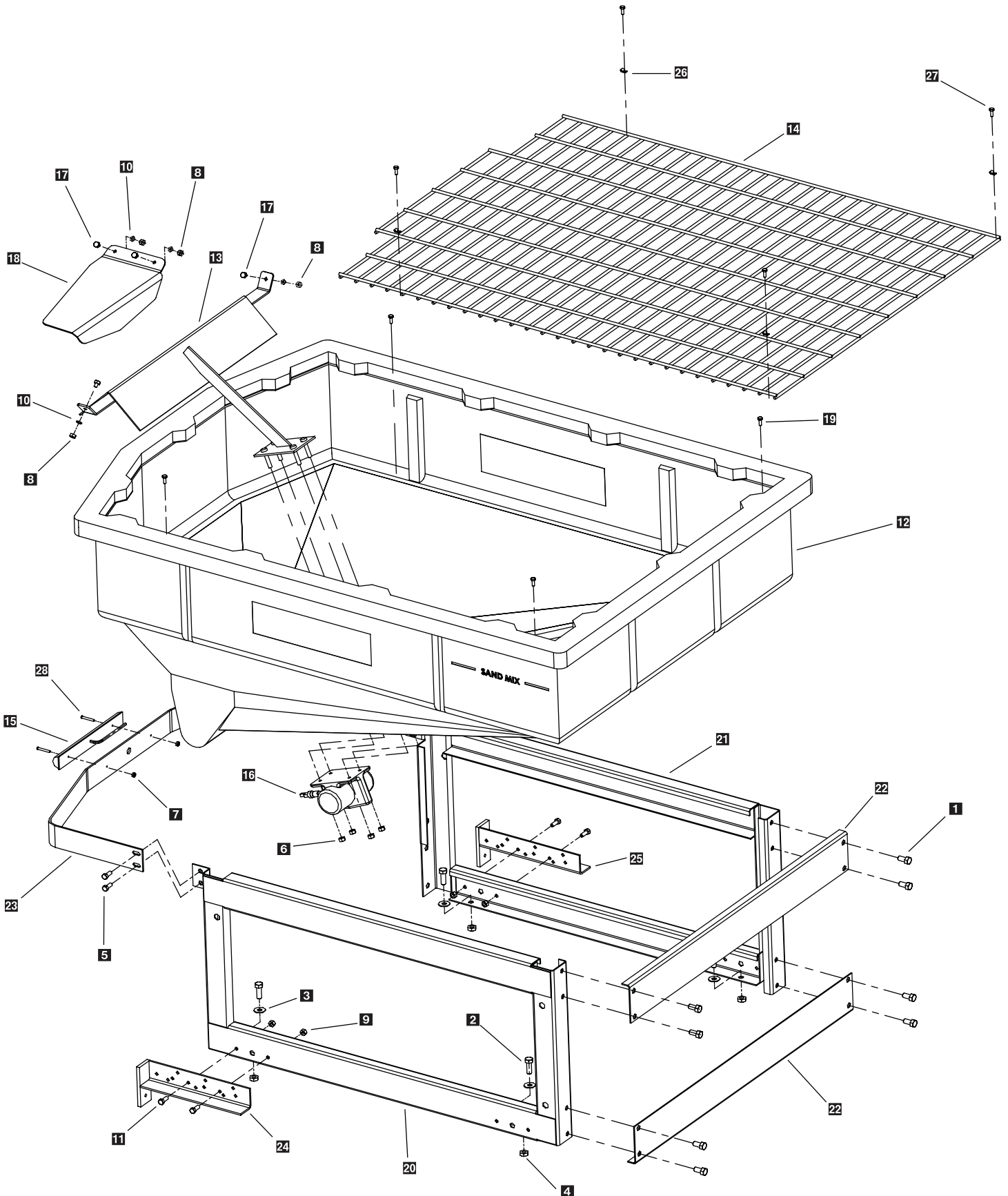

Main Assembly Parts Breakdown

Model # SP-6000



Key	Part No.	Description	Qty.
1	D 6528	1/2" - 13 x 1" Serrated Flange Hex Bolt	8
2	D 4116	1/2" - 13 x 1-1/2" Hex Bolt	4
3	D 4119	1/2" Flat Washer	4
4	D 4120	1/2" Lock Nut	4
5	D 6452	3/8" - 16 x 1" Hex Bolt Serrated HWH Type F	4
6	D 6584	3/8" Serrated Lock Nut	4
7	D 6158	#10 Lock Nut	2
8	D 6138	5/16" Lock Nut	4
9	D 4124	3/8 Lock Nut	4
10	D 6165	5/16" Flat Washer	4
11	D 4121	3/8" - 16 x 1" Hex Bolt	4
12	D 6500	6000 Vee Hopper	1
13	D 6504	Inverted Vee	1
14	D 6506	6000 Top Screen	1
15	D 6514	CHMSL Brake Light	1
16	D 6515	Heavy Duty Vibrator	1
17	D 6524	5/16" - 18 x 1-1/2" Tap Bolt	4
18	D 6577	Baffle	1
19	D 6874	#14 x 1-1/4" Self Drill TEK	4
20	D 6530	6000 Right Frame Weldment	1
21	D 6531	6000 Left Frame Weldment	1
22	D 6532	Upper/Lower Front Facia	2
23	D 6533	Hopper Apron	1
24	D 6536	Adj. Stop Bracket RT	1
25	D 6537	Adj. Stop Bracket LT	1
26	D 6509	Top Screen Hold Down	4
27	D 6553	Top Screen Hold Down Screw	4
28	D 6529	#10 Black Oxide Screw	2

Spinner Drive Assembly Parts Breakdown

Model # SP-3000/SP-6000

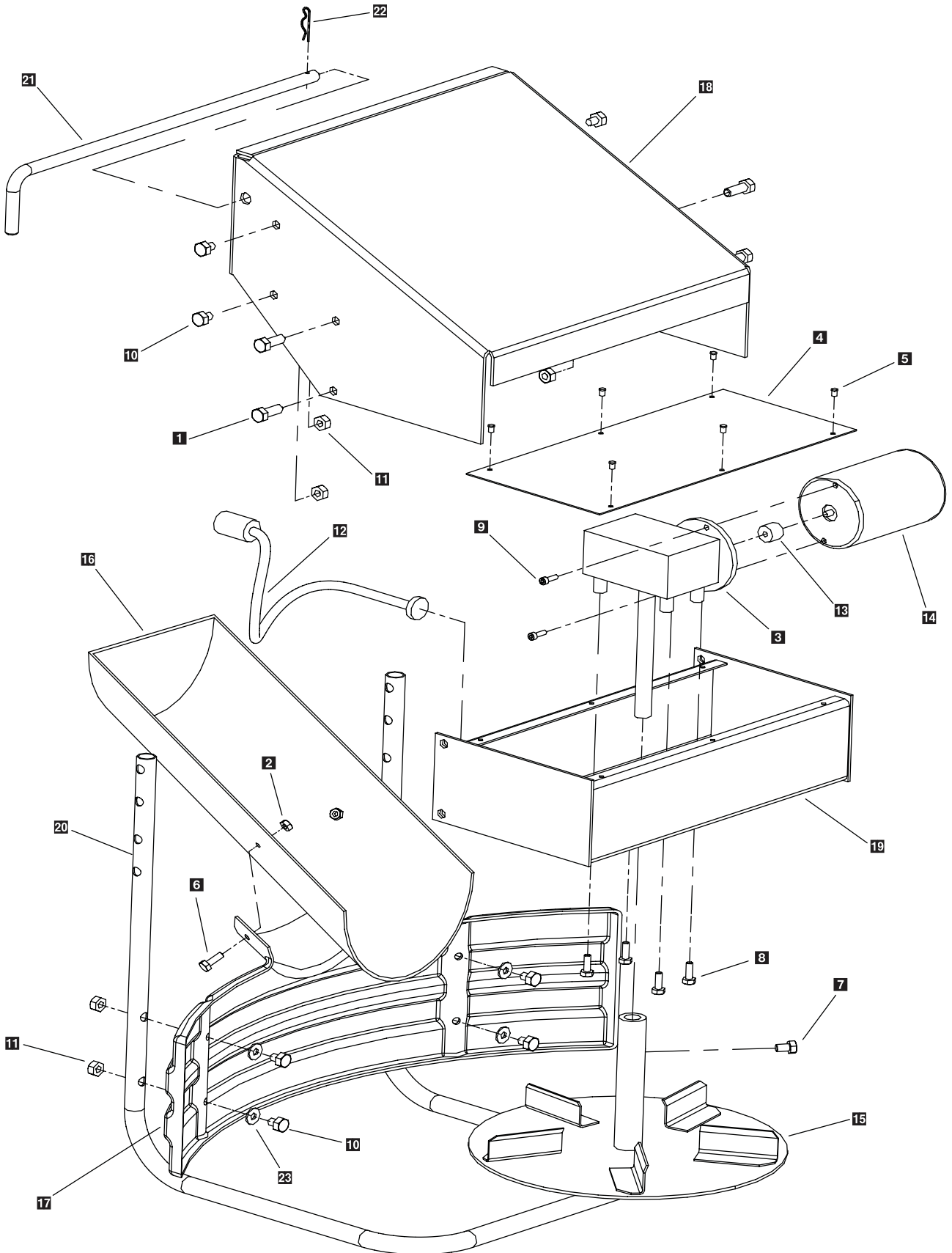

Spinner Drive Assembly Parts Breakdown

Model # SP-3000/SP-6000



Key	Part No.	Description	Qty.
1	D 6452	3/8" - 16 x 1" Hex Bolt	4
2	D 4289	1/4" Lock Nut	4
3	D 6107	Transmission	1
4	D 6109	Motor Cover	1
5	D 6467	Plastic Push Fastener	6
6	D 6854	1/4" - 20 x 1" Stainless Hex Bolt Flange Head	4
7	D 6133	5/16" - 18 x 1/2 Hex Bolt	1
8	D 6131	1/4" - 20 x 1/2 SS Flange Bolt	4
9	D 6172	#10 - 32 x 5/8" Serrated Flange Bolt	2
10	D 6462	5/16 - 18 x 1-1/2" Bolt	8
11	D 6138	5/16" Lock Nut	10
12	D 6162	24" Power Cable	1
13	D 6232	Motor Drive Coupler	1
14	D 6106	Spinner Motor	1
15	D 6516	12" Spinner w/Extended Shaft	1
16	D 6517	Chute	1
17	D 6564	Deflector	1
18	D 6575	Drive Enclosure Shroud	1
19	D 6541	Spinner Drive Enclosure	1
20	D 6543	Tubular Spinner Guard	1
21	D 6563	Pin	1
22	D 4135	Hair Pin Clip	1
23	D 6165	5/16" Flat Washer	4

Complete Drive Assembly D 6565

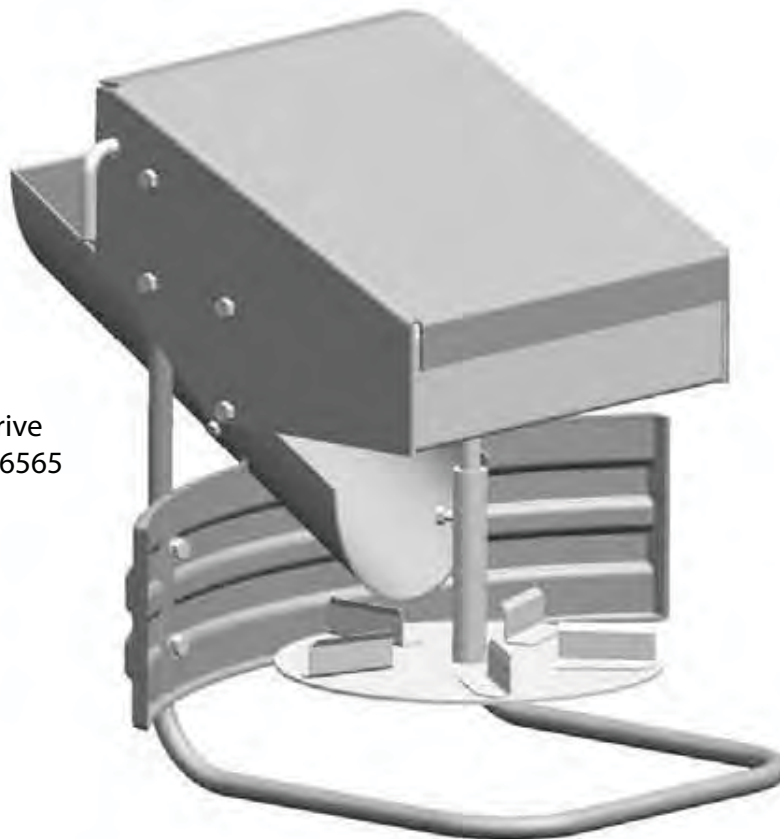

Vehicle Harness Wiring Instructions



Model # SP-3000/SP-6000

Step 1: Take harness assembly and route from the rear of the vehicle to the front. Route harness along frame and attach to frame holes and frame supports. It is not recommended to attach to fuel or brake lines for obvious reasons. Do not route close to exhaust system or engine, even though Snowex uses high temperature wiring. It still could melt under extreme heat and short the spreader electrical system, as well as the vehicle electrical system.

Step 2: Mount rear plug on bumper using supplied bolts, locate towards the center of the bumper to reduce the amount of debris the tires will throw to the rear. Important: Apply a small amount of dielectric grease to the plug. Also try to mount so plug faces upward to help keep plugs tightly sealed.

Step 3: Secure harness from the rear to the front using heavy duty ty-wraps or frame clips along the frame and lighter duty ty-wraps everywhere else.

Step 4: Layout harness portion that connects to the battery along the fire wall and fender well. Do not connect power leads to battery yet. Drill a 3/4" hole in the fire wall, or use existing access hole, for the control portion of the harness and route connector and harness through hole. Be sure to check the area on the other side of the fire wall to make sure you are not drilling into the vehicle harness or a control module. Generally you can drill on either side of the steering wheel for a good location.

Step 4A: The power harness from control box to battery will need to be routed from the inside of the cab to the battery – this results from the large high amperage connector. Route leads with lugs to battery — do not connect power at this time.

Step 5: Connect harness to the back of the controller and mount to a suitable location. NOTE: You may want to contact customer before mounting controller, some prefer not to have holes drilled into the dashboard. Ty-wrap loose controller harness and move to the engine compartment. Do not mount close to any heater vents.

Step 6: Connect power leads to the battery: Red + Positive, Black – Negative, always connect to the primary battery if using a dual battery system, secure loose loom to any other large or medium vehicle harness with medium duty ty-wraps; this will secure wiring harness.

Step 7: Push the ON/OFF button on the controller to check for power, when that has been confirmed turn power **OFF**. The electrical portion of the installation is complete.

Assembly View
Model # SP-3000/SP-6000

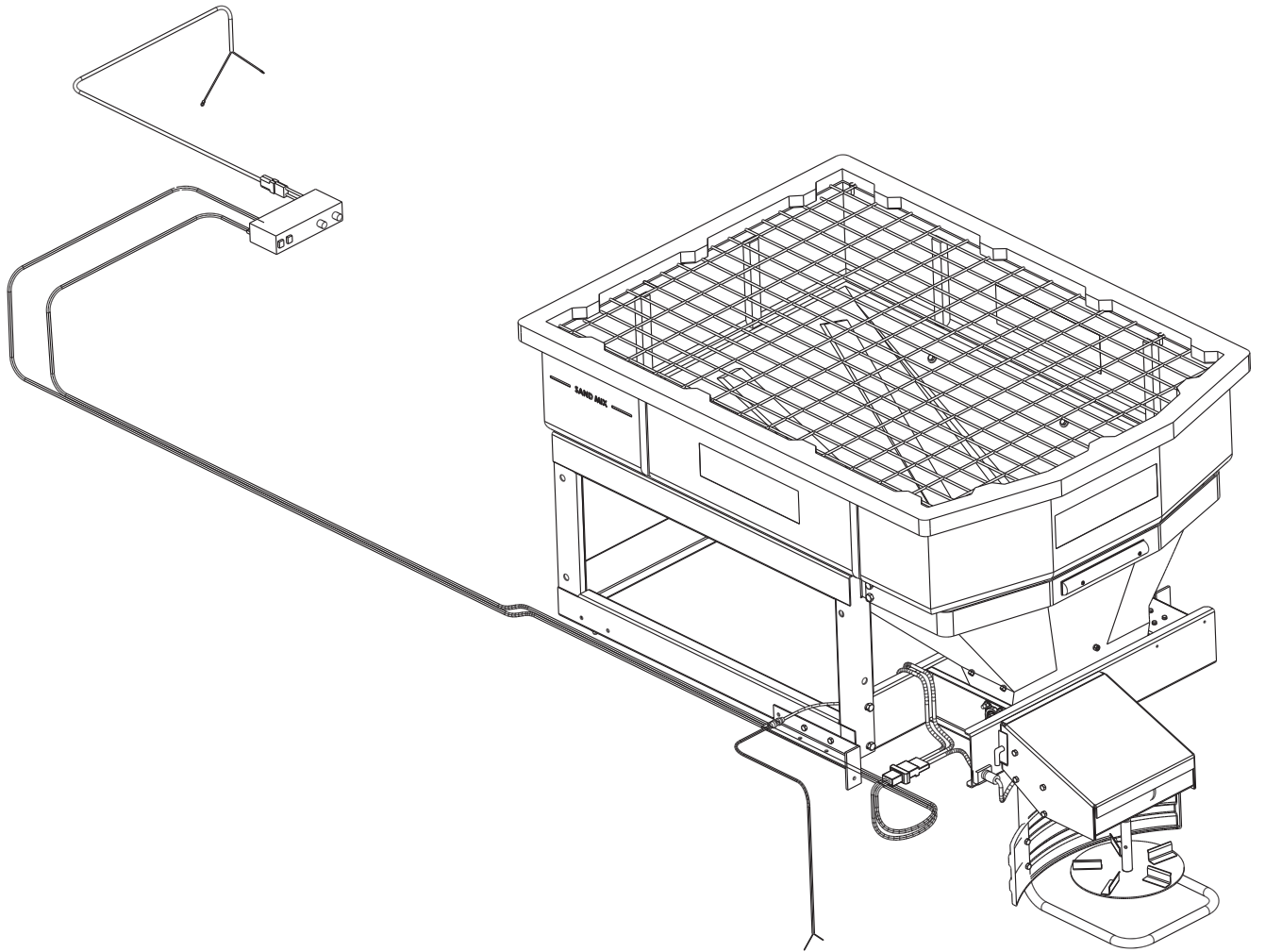

Electrical System Parts Breakdown

Model # SP-3000/SP-6000

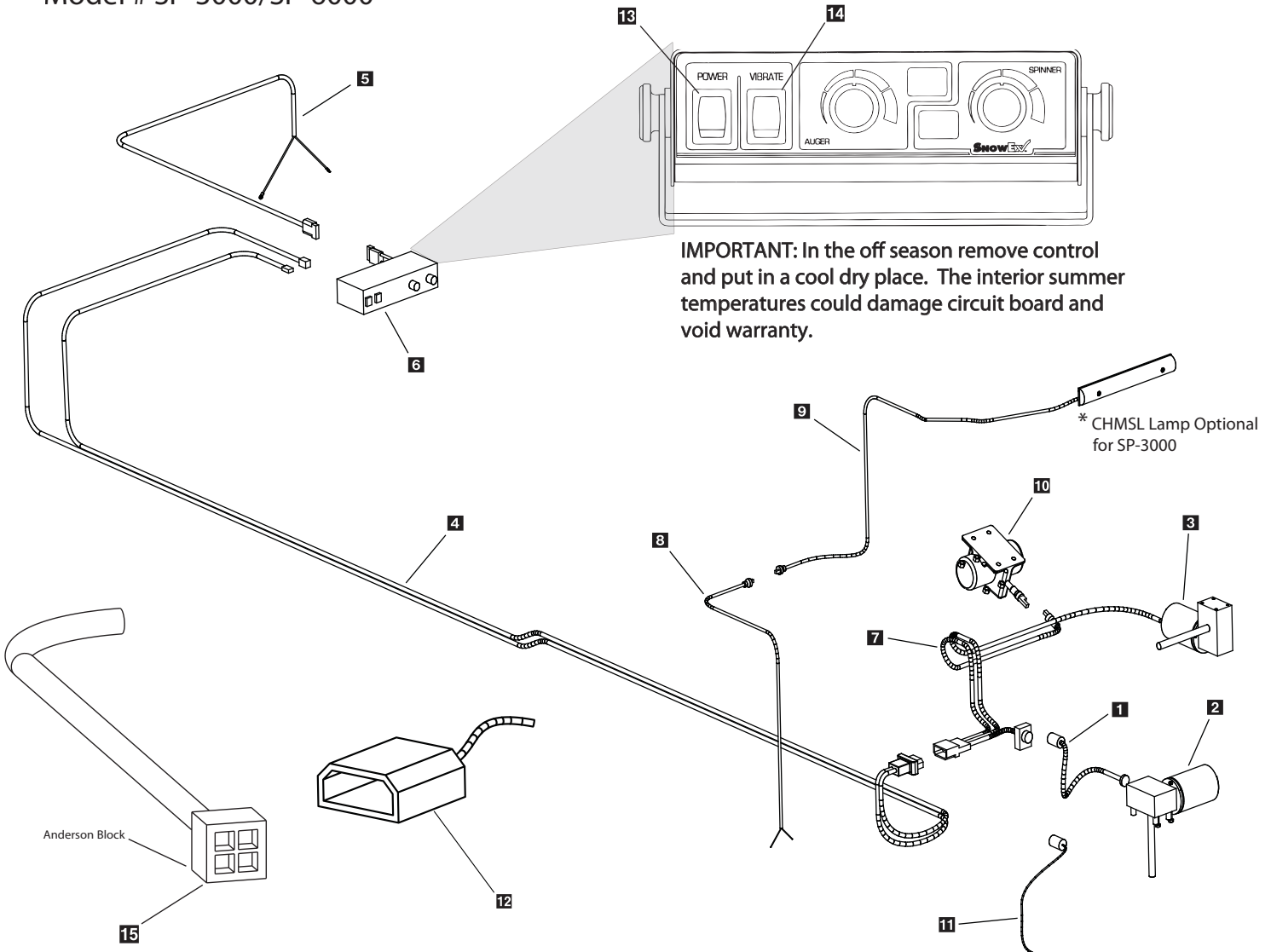

IMPORTANT: In the off season remove control and put in a cool dry place. The interior summer temperatures could damage circuit board and void warranty.

* CHMSL Lamp Optional for SP-3000

IMPORTANT: Do not modify harness length. Any modifications will void warranty.

Special Notes:

1. All external connections must have dielectric grease.
2. Read lead labels before attaching to power source or ground.
3. No other devices may be spliced into wiring harness.
4. Any repairs to wiring harness must be done with heat shrink butt connectors.
5. If inline fuse is installed, use a 60 amp maxi fuse or circuit breaker.

SPINOTTO TIPO A



SPINOTTO TIPO B

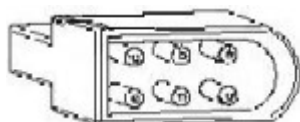

Key	Part No.	Description	Qty.
1	D 6162	Power Cable	1
2	D 6106	Spinner Motor	1
3	D 6320	Auger Motor	1
4	D 6322	Vehicle Harness - 25'	1
5	D 6341	Control Power Cable	1
6	D 6527	Controller	1
7	D 6511	Power Cord - 54"	1
8	D 6513	CHMSL Harness (*see note)	1
9	D 6514	CHMSL Brake Light (*see note)	1
10	D 6515	Heavy Duty Vibrator	1
11	D 6118	Dust Cap Spinner Plug	1
12	D 6343	Dust Cap Vehicle Plug	1
13	D 6237	5 Terminal Control Power Switch	1
14	D 6354	3 Terminal Vibrator Switch	1
15	D 6170	Anderson Connector With Leads	1

Pos.4 D6322 N.B. verificare se con spinotto tipo A oppure B
 Pos.4 D6322A cod. 8520051
 Pos.4 D6322B cod. 8520068

Electrical Routing

Model # SP-3000/SP-6000

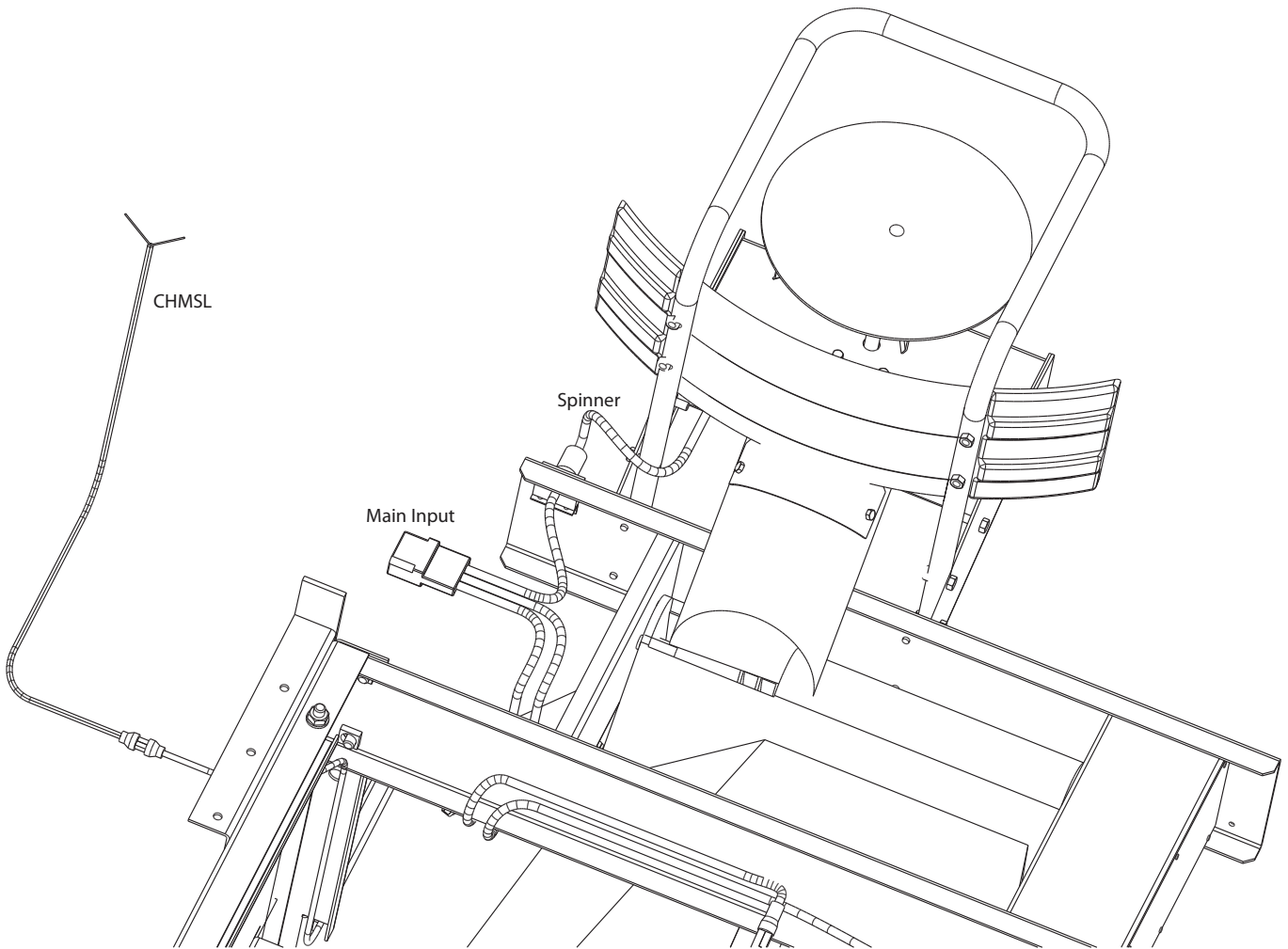

Auger and Vibrator (not supplied on drawing)

Controller Wiring Diagram

Model # SP-3000/SP-6000

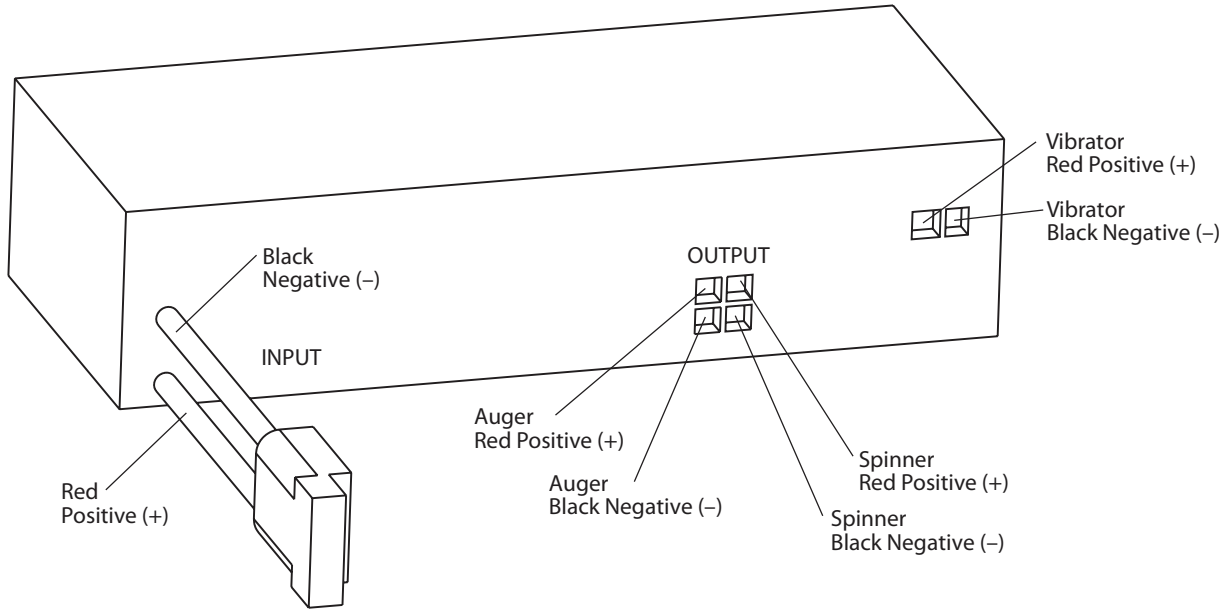

IMPORTANT: In the off season remove control and put in a cool dry place. The interior summer temperatures could damage circuit board and void warranty.

Control Power Cable

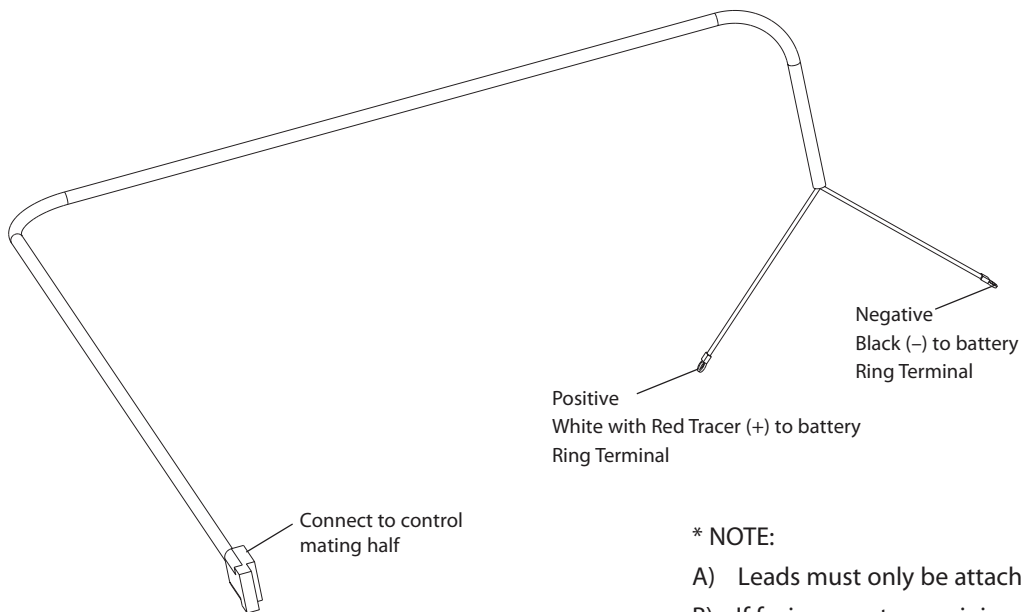

*** NOTE:**

- A) Leads must only be attached to battery.
- B) If fusing, must use minimum 60 Amp Maxi type fuse or circuit breaker.

Spreader Power Harness Circuit Diagram

Model # SP-3000/SP-6000

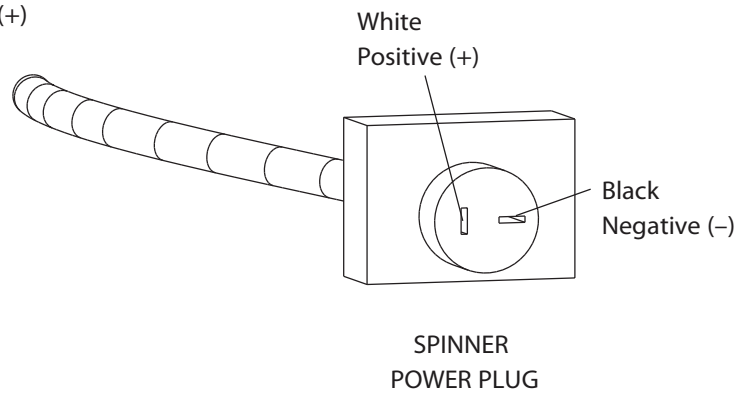
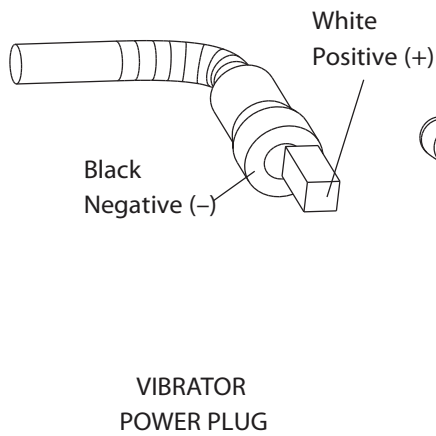
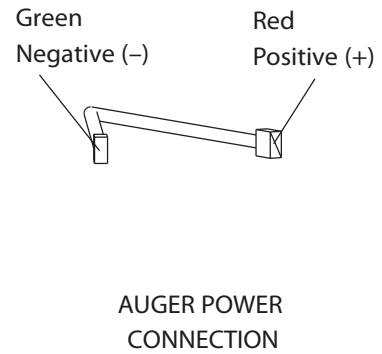
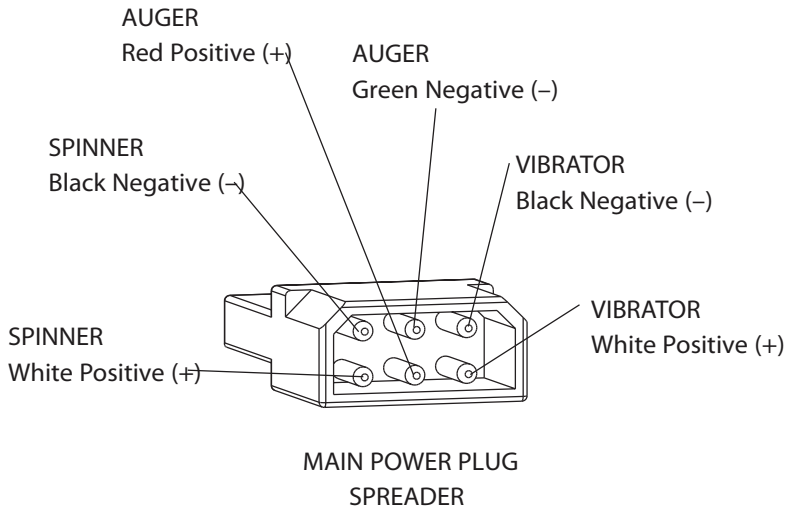

* NOTE: Plug has polarity reversed for proper motor rotation

Vehicle Harness Circuit Diagram

Model # SP-3000/SP-6000

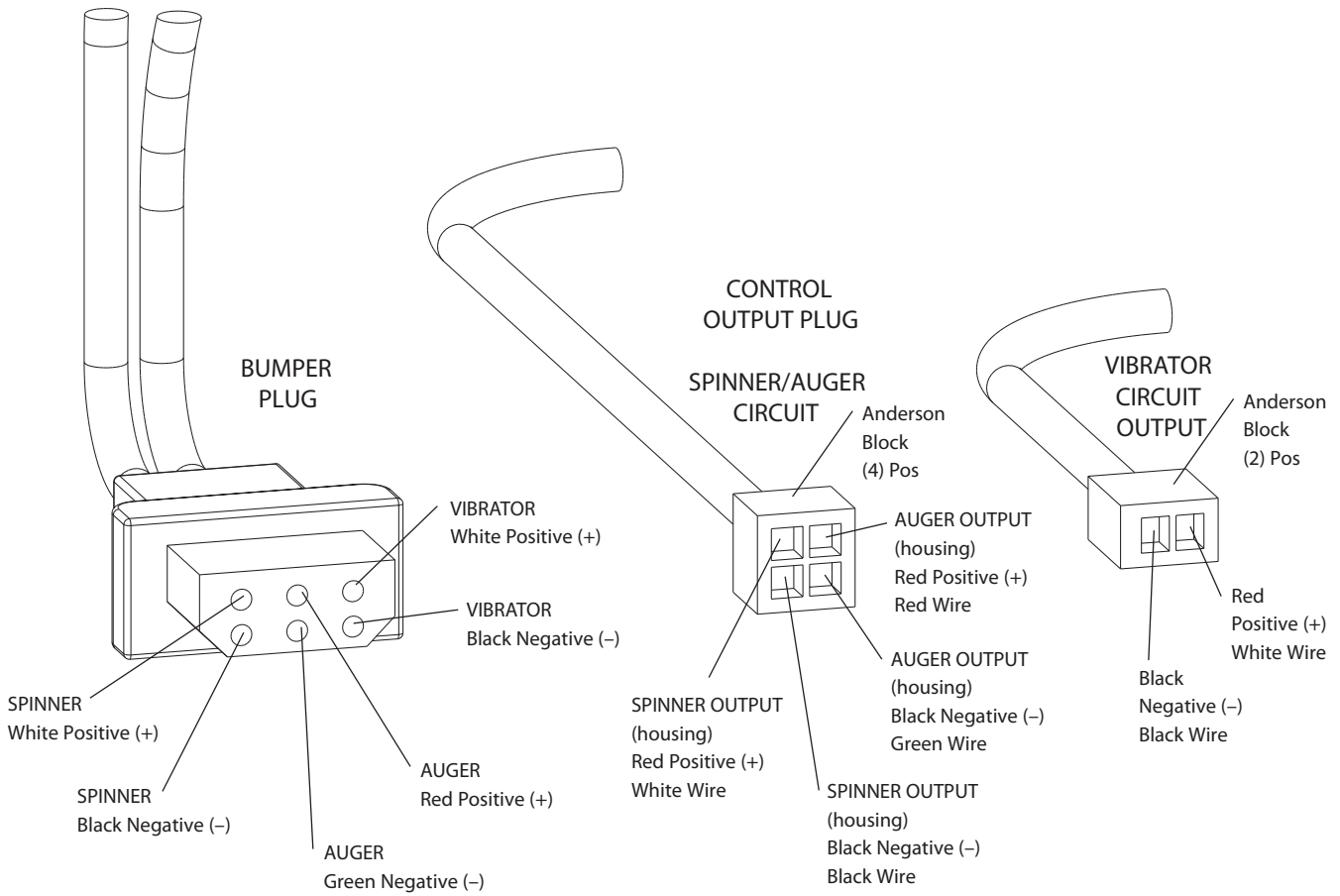

* NOTE: Reference Bumper Plug for Color Code

Center High Mount Stop Lamp (CHMSL)

Model # SP-6000



Vee Pro 6000

- With spreader mounted on vehicle, plug vehicle (CHMSL) harness into spreader stop lamp harness.
- Using supplied harness clamps and screws, route harness along side wall lower corner or so that harness will be out of the way when spreader is in use.
- Locate vehicle ground wire and stop lamp power wire at rear of vehicle. Use supplied wire taps to connect harness to vehicle electrical system. Once wire taps are installed check to make sure stop lamp works when brake pedal is pressed. Properly complete installation by tying up any loose wires with ty-wraps, also add electrical tape over both connections to insure a solid electrical connection. Some newer trucks have auxiliary stop lamp power leads already at the rear for these types of applications.

CHMSL Spreader Harness (installed on Spreader from factory)

Key	Part No.	Description	Qty.
1	D 6158	#10 Lock Nut	2
2	D 6514	CHMSL Spreader Harness	1
3	D 6529	#10 Black Oxide Screw	2

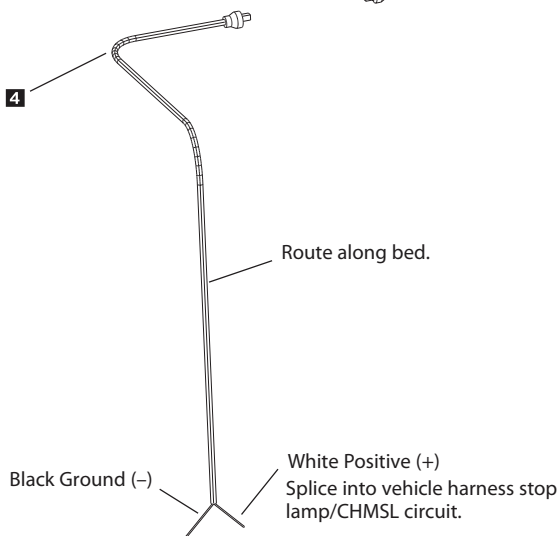
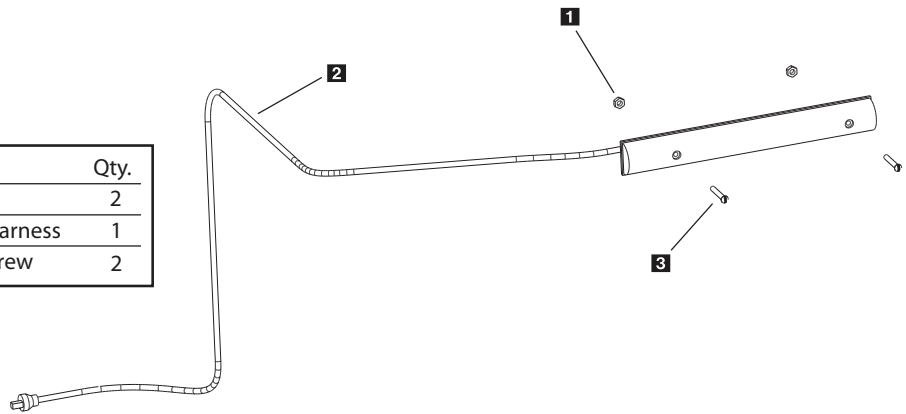

CHMSL Vehicle Harness

Key	Part No.	Description	Qty.
	D 6234	Butt Connectors	2
4	D 6513	CHMSL Vehicle Harness	1
	D 6523	Scotch Locks	2
	D 6560	Hex Head Screw	4
	D 6561	Cable Mounts	4

Mounting Instructions

Model # SP-3000/SP-6000

Step 1: Remove tailgate from pickup bed.

Step 2: Load spreader onto truck bed and mount spinner assembly.

Step 3: Slide spreader forward until deflector/chute assembly makes contact with vehicle. Then, slide spreader back approx. 1" to allow proper clearance.

Step 4: Install stop bars using supplied hole patterns (see Fig.2). To achieve the best position, you may need to drill additional holes in bracket in order to properly position spreader.

Step 5: Now that the spreader is positioned front to back, you will now center it left to right. Looking at the inside front and rear corner of the lower frame area, you will notice (4) holes in the bottom of the frame. Using a paint pen or similar marking device, mark hole locations.

Step 6: Before drilling holes, look beneath the approximate area where each hole will be located. Make sure there are no vehicle components that will be in the path of the drill before doing this step. If there are interferences, you can relocate holes, making sure there are at least two forward and two rearward of the front to back centerline.

Step 7: Install and tighten all (4) bolts.

Step 8: Install ratchet straps (see Vee Pro 3000/6000 Mounting System: Strapping Techniques). It is very important for everyone's safety this strapping method be used as the standard mounting procedure.
(Do not use ratchet straps exclusively.)

Step 9: Connect the spreader power cord to vehicle main power plug mounted at rear of vehicle (see Electrical Installation).

Step 10: Connect Center High Mount Stop Lamp (CHMSL) cord from the spreader to mating half attached to vehicle (see Electrical Installation).

Mounting System Strapping Techniques

Model # SP-3000/SP-6000

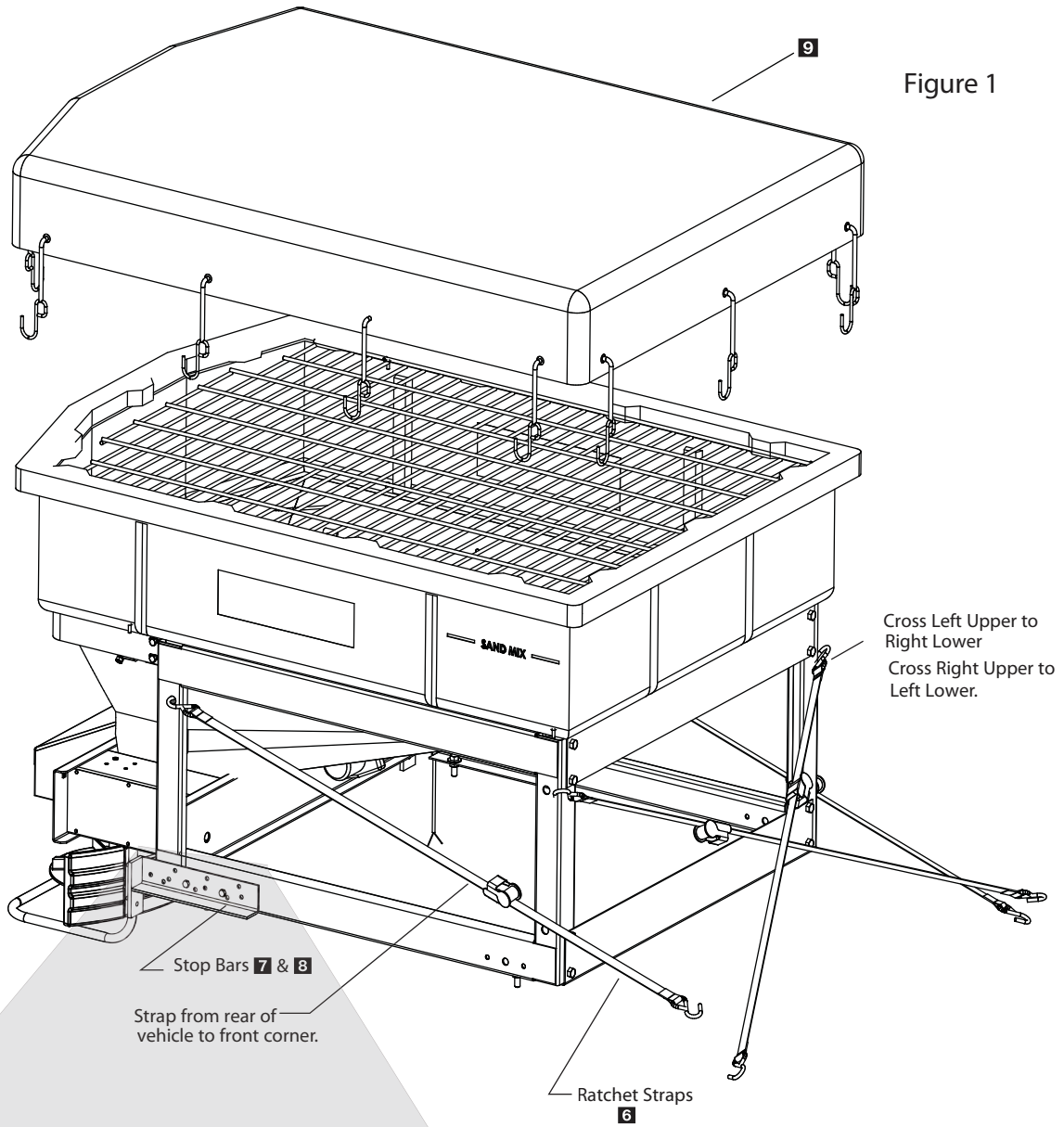
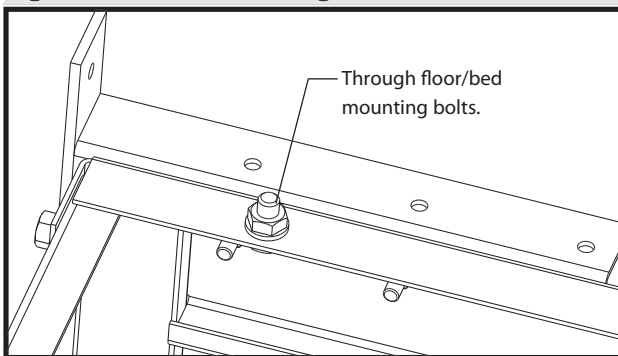

Figure 1

Figure 2: Frame Mounting Bolts



Key	Part No.	Description	Qty.
1	D 4116	1/2" - 13 x 1-1/2" Hex Bolt	4
2	D 4119	1/2" Flat Washer	4
3	D 4120	1/2" Lock Nut	4
4	D 4121	3/8 - 16 x 1" Hex Bolt	4
5	D 4124	3/8" Lock Nut	4
6	D 6503	Ratchet Strap	4
7	D 6536	Adj. Stop Bracket RT	1
8	D 6537	Adj. Stop Bracket LT	1
	D 6499	Vee Pro 3000 Tarp	1
9	D 6510	Vee Pro 6000 Tarp	1
	D 6522	Bungie Straps (15 pcs. Per Pkg)	1

Express Mount Kit Parts Breakdown



Model # XMT-175

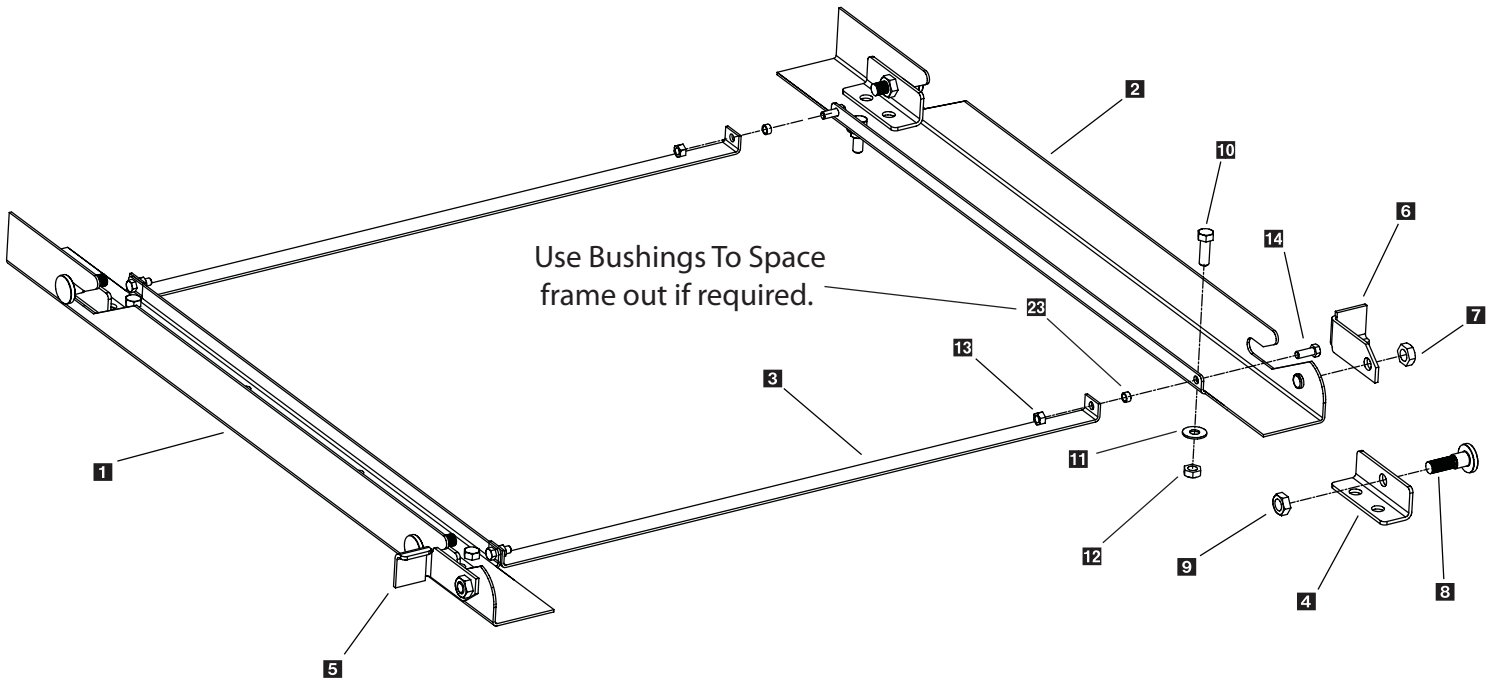

NOTE: Kit will not work with the Vee Pro 3000.

Key	Part No.	Description	Qty.
1	D 6590	Mounting Rail Left	1
2	D 6589	Mounting Rail Right	1
3	D 6591	Cross Rail	2
4	D 6595	Backing Plate	4
5	D 6593	Stop Latch Lt Side	1
6	D 6592	Stop Latch Rt Side	1
7	D 6573	5/8" Thin Lock Nut	2
8	D 6594	Special Stop Bolt	4
9	D 4127	5/8" Lock Nut	4
10	D 4116	1/2-13 x 1-1/2" Hex Bolt	8
11	D 6581	1/2" Fender Washer	8
12	D 4120	1/2" Lock Nut	8
13	D 4124	3/8-16 Lock Nut	5
14	D 4121	3/8-16 x 1" Hex Bolt	4
15	D 6572	Wheel Ball Pin	1
16	D 6567	Wheel Cross Bar	1
17	D 6570	Wheel Pivot w/Lock	2
18	D 6576	5/16-18 x 1-1/4" Hex Bolt	12
19	D 6138	5/16-18 Lock Nut	12
20	D 6568	Wheel Foot Holder	1
21	D 6569	Wheel Arm	1
22	D 6587	3/8-16 x 2-1/2 HHCS Bolt	1
23	D 5717	Nylon Spacer Bushing	4

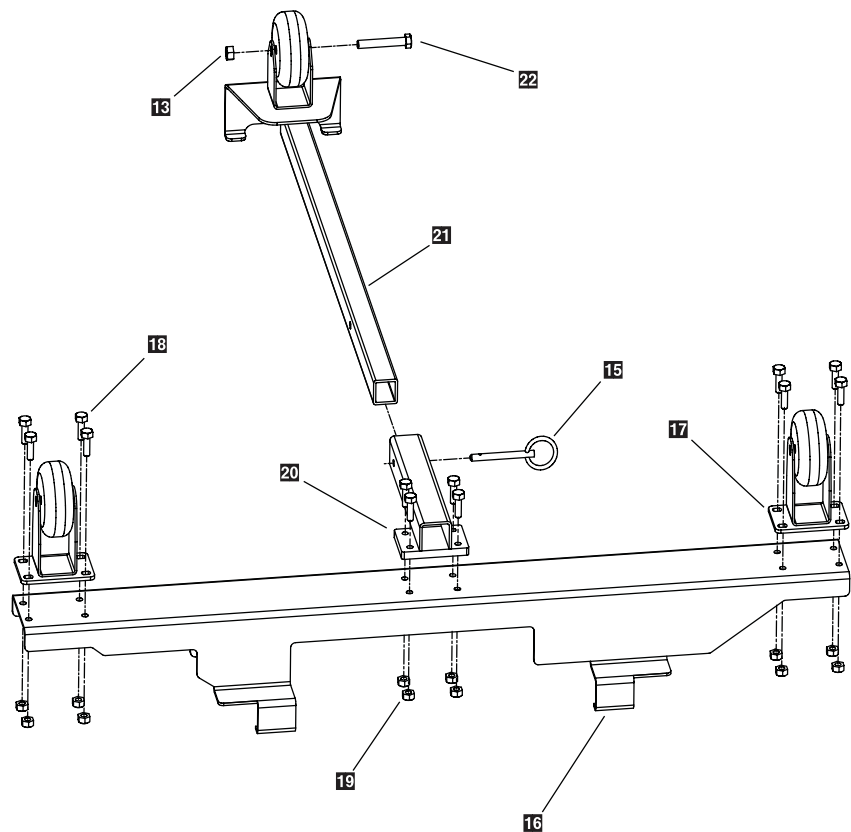

Mounting Instructions

Model # XMT-175

IN BED EXPRESS MOUNT

- Step 1: Locate left and right side mounting rail **1** and **2**.
- Step 2: Locate item **3** cross rails.
- Step 3: Assemble items **1**, **2** and **3** together per exploded view. (Accessory Shim **25** may be needed for adjustment.)
- Step 4: Install rear latches items **5** and **6** with 5/8" thin lock nut **7**.
- Step 5: Place frame assembly on truck and center left to right.
- Step 6: Install items **4**, **8** and **9** per illustration. Note: on older models, you will have to drill out frame to accept item **8** stop bolt. To do this, you will need to bolt item **4** to lower frame rail using a drill template to locate the bracket, drill all four holes and then install items **4**, **8** and **9**.
- Step 7: Determine front to back location by either placing spreader into locked position on frame assembly or by measuring using rear side frame holes and measuring to rear of pick up bed. Mark holes with paint marker or scribe. Verify that there are no critical components below the pick up bed such as a gas tank, etc.
- Step 8: Drill holes and mount frame using supplied 5/8" hardware. Note: There are alternate holes for drilling around items that may be in the way.

WHEEL KIT

- Step 1: Assemble item **17** to item **16** using supplied hardware.
- Step 2: Assemble items **20** to item **16** using supplied hardware.
- Step 3: With spreader in truck, place item **21** wheel arm on the rear center of upper rail of hopper (see illustration/pictures.)
- Step 4: Place item **16** on auger weldment and trap the lower edge while at the same time positioning item **21** to engage item **20** so that item **15** pin with ring can keep the two assemblies together.
- Step 5: Lock swivel wheels.
- Step 6: Pull spreader back and off the in bed mount, allow spreader to rotate towards ground with the locked wheels touching first.
- Step 7: Continue to pull spreader into a vertical position.
- Step 8: When everything is stable, release wheel locks and slowly move spreader to storage location. Lock wheels when final place has been established.
- Step 9: See photo and drawing illustrations for assembly and installation.

Note: Ratchet straps must still be used as part of the mounting system.

Optimum Flow Installation Instructions

Model # OFK-020

Step 1: Remove original baffles and plug holes with supplied hardware.

Step 2: Position new style baffle so there are no gaps; baffle is designed to be self locating.

Step 3: Mark and drill holes.

Step 4: Install supplied hardware the same way as original baffle was. Nut and washer should be on exterior surface.

Step 5: Center the Optimum Flow vibrator horizontally and 6-1/2" below apron; (see illustration below) mark and drill holes.

Step 6: Mount vibrator with cord pointing down using supplied hardware. Please note: there is a vibrator backing plate that must be positioned properly. Please refer to standard vibrator instructions for details regarding harness installation, etc.

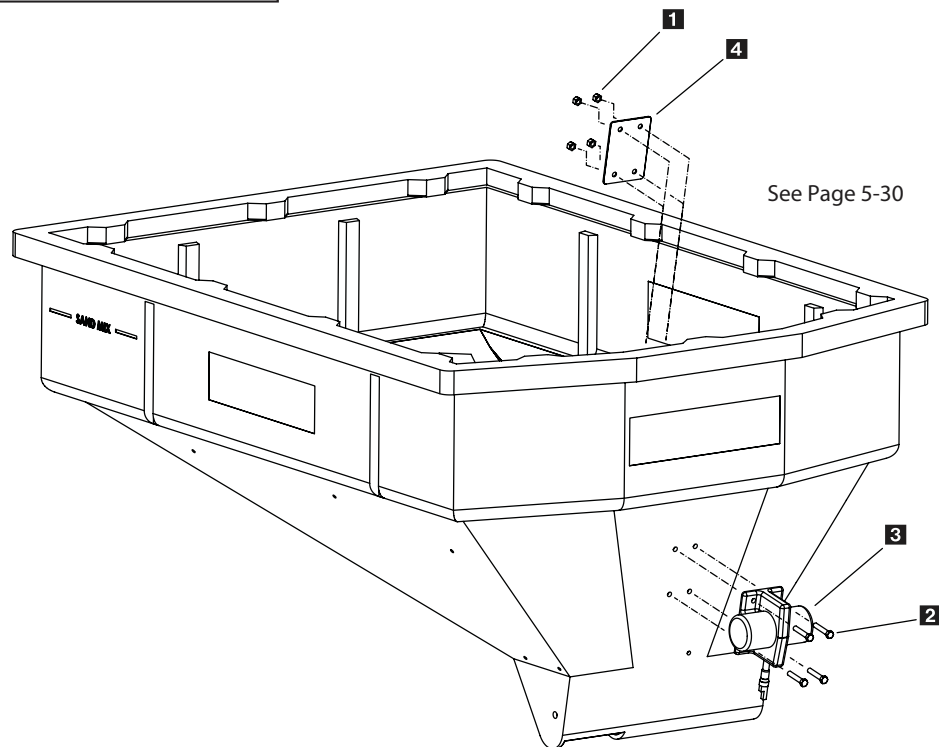
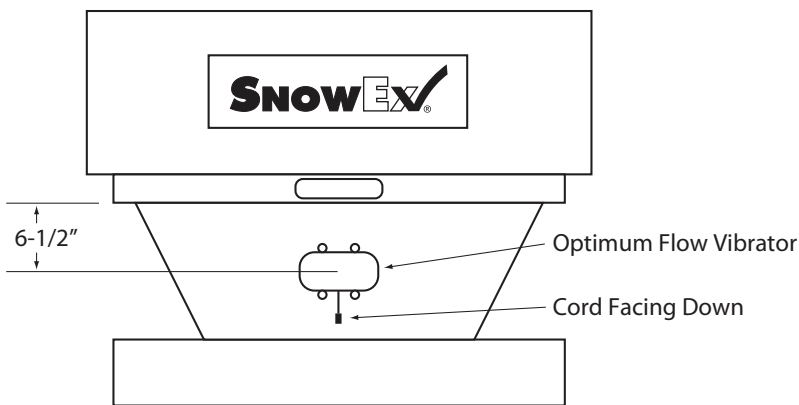

Optimum Flow Kit Diagram and Instructions

Model # OFK-020

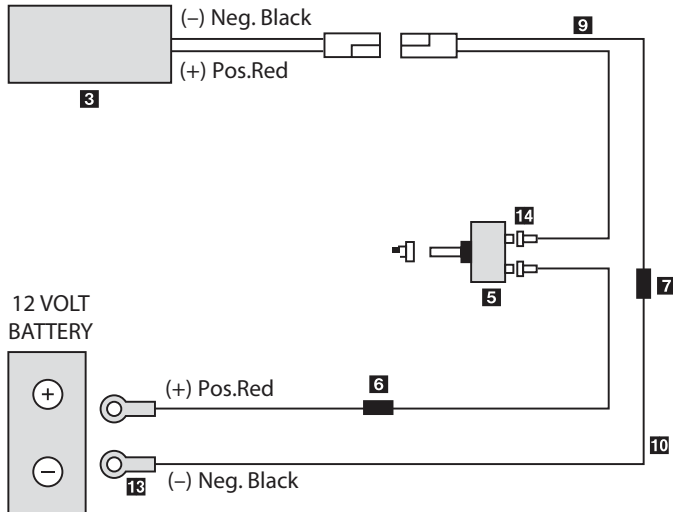

Key	Part No.	Description	Qty.
1	D 4124	3/8" Lock Nut	4
2	D 6160	3/8" - 16x2 Hex Bolt	4
3	D 6161	DC-80 Vibrator	1
4	D 6579	Vibrator Backing Plate	1
5	D 6184	On/Off Switch	1
6	D 6233	10 Amp Fuse	1
7	D 6234	Butt Connector	1
8	D 6344	Dielectric Grease	1
9	D 6403	20' Universal Harness	1
10	D 6404	10' Battery Harness	1
11	D 6406	Rubber Switch Boot	1
12	D 6425	Fuse Holder	1
13	D 7105	Ring Terminal	2
14	D 7106	Spade Connector	2
15	D 6578	Opti-Flow Baffle	1

Wiring Installation and Instructions

Step 1: First, install switch at desired location. This will determine what the proper wire length should be.

Step 2: Run spreader/vehicle harness from the rear of vehicle to switch area. Remove approx. 3" of the black outer jacket exposing two single leads (red and black), strip a 1/4" off each lead. Crimp 1/4" female connector on red lead and crimp the butt connector to the black lead. Place the female spade/red wire to the on/off switch and leave the black wire for the next step.

Step 3: Route the power harness from the battery to the switch; this will determine proper length to cut wires. Repeat step #2 regarding cable jacketing and connection points to the switch and butt connector.

Step 4: Install an inline 10 amp. fuse on the positive (red) lead from the battery to the switch. Locate an easily accessible place, out of the elements, for the fuse and remove approx. 3" of the black outer jacket exposing two single leads (red and black). Cut the red lead in half and strip a 1/4" off each lead. Insert into the fuse connector and crimp. Insert 10 amp. blade fuse into connector.

Step 5: At the battery end of the power harness, remove 8" of the black outer jacket exposing two single leads (red and black). Strip 1/4" off each lead. Crimp a 3/8" lug terminal to each lead and attach the red lead to the positive side of the battery and the black lead to the negative side of the battery.

Step 6: Locate vibrator approx. 6" to 8" from the top of throat entry and drill four 3/8" holes in rear hopper face. Bolt the vibrator in place using nuts and bolts provided, with backing plate inside hopper.

IMPORTANT: It is imperative that the vibrator backing plate is used (see page 5-29) . Use of any other method could cause hopper to tear.

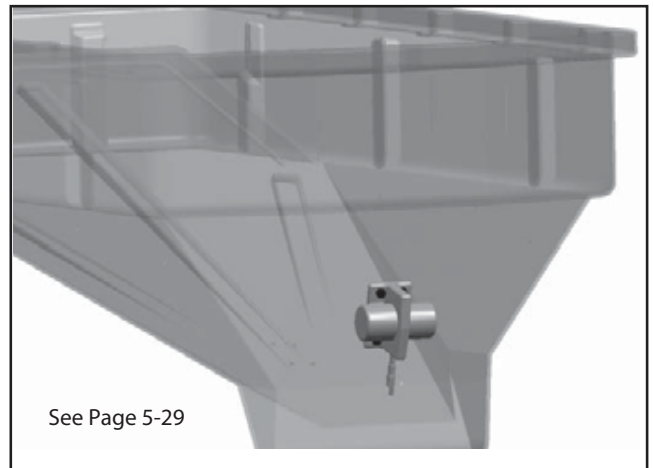

Adjustable Baffle Kit



Model # ABK-020 (For SP-3000 Spreader Only)

Remove original factory baffle and replace with new baffle assembly (exploded view) or in separate stages.

- 1** D 6497 (first stage) is for wet sand/wet salt/or a wet blended mix.
- 2** D 6498 (second stage) attached to the first stage; is for dry coarse free flowing materials.
- 3** D 6499 (final stage) attached to the second and first stage; is for fine materials or ice melters.

Key	Part No.	Description	Qty.
1	D 6471	Baffle 1 (wet material)	1
2	D 6472	Baffle 2 (dry coarse material)	1
3	D 6473	Baffle 3 (fine material)	1
4	D 6524	5/16"-18 x 1-1/2" Tap Bolt	2
5	D 6165	5/16" Flat Washer	2
6	D 6138	5/16"-18 Lock Nut	2
7	D 6452	3/8-16 x 1 Serrated Flange Bolt	4

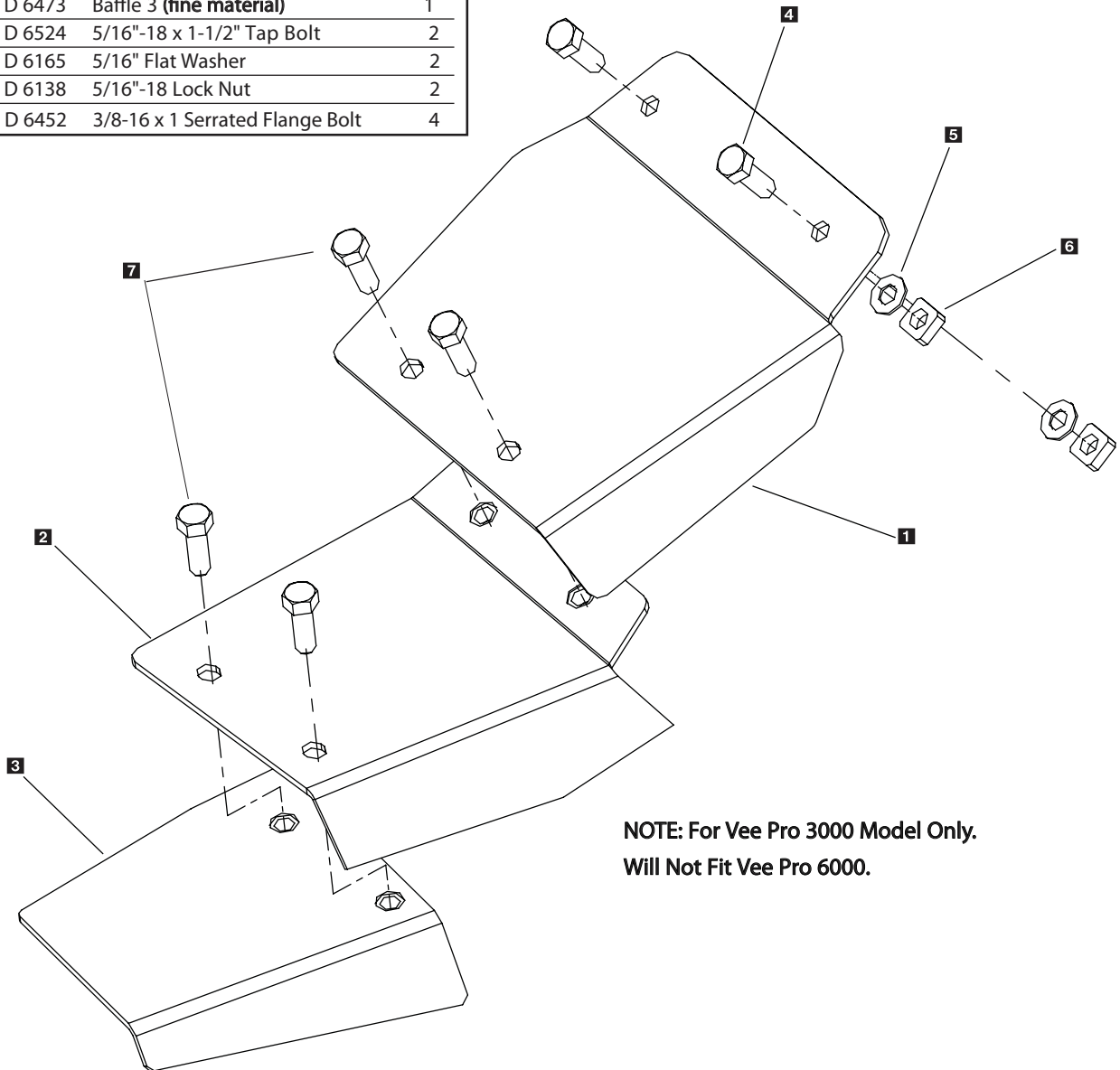

**NOTE: For Vee Pro 3000 Model Only.
Will Not Fit Vee Pro 6000.**

Operating the Spreader

Model # SP-3000/SP-6000



PREPARATION

CAUTION – Sweep area clear of foreign objects or obstacles that could cause personal injury. Keep other persons, children, or animals out of the area to be spread.

SPREADER LOADING

WARNING – Do not overload vehicle. Use chart below to calculate weight of material. Weights of material are an average for dry materials.

<u>Material</u>	<u>Weight Per Cubic Ft.</u>
Rock Salt	35-40 lbs.
Sand/Salt Mix	95-120 lbs.

- Be sure to comply with manufacturer's maximum gross vehicle weight ratings.
- Warning– Never leave materials in hopper for long periods of time as salt is hygroscopic and will attract atmospheric moisture and harden up. When spreading sand mix, a 1:1 ratio for Sand/Salt mix is recommended to prevent the material from freezing.

SPREADING TIPS

- Never exceed 10 m.p.h. when spreading.
- For a wider pass, increase spinner speed.
- For a heavier pass, drive slower, or increase auger speed.
- Never operate spreader near pedestrians.
- Spread ice melters with the storm to prevent unmanageable levels of ice.
- Calculate spread pattern when near vegetation.

SP-3000/SP-6000 CONTROL OPERATION

- The Dual Variable Speed Control has dual finger-tip dials for maximum performance, digital system status with warning protection and built-in Vibrator Switch.
- To start, press power switch on controller and spreader will accelerate to speed set on spinner and auger dials.
- To stop, press power switch on controller to off position.
- Speed of auger and spinner may be adjusted separately to get desired flow and spread distance from spreader.
- The Vibrator Switch is needed for dense material or to increase the flow to the auger. This eliminates bridging of material in hopper.

Operating the Spreader (continued)



Model # SP-3000/SP-6000

BAFFLE INSTRUCTIONS

- The Vee Pro 3000/6000 uses a single baffle design over the auger area. This baffle is used for salt/sand mixtures of 50% sand and 50% salt.
- **WARNING:** Always disconnect power source before attempting to remove material baffle.
- The main baffle (D 6577) **MUST** never be removed from its original factory installed position unless the unit is being serviced or installing Optiflow Kit.

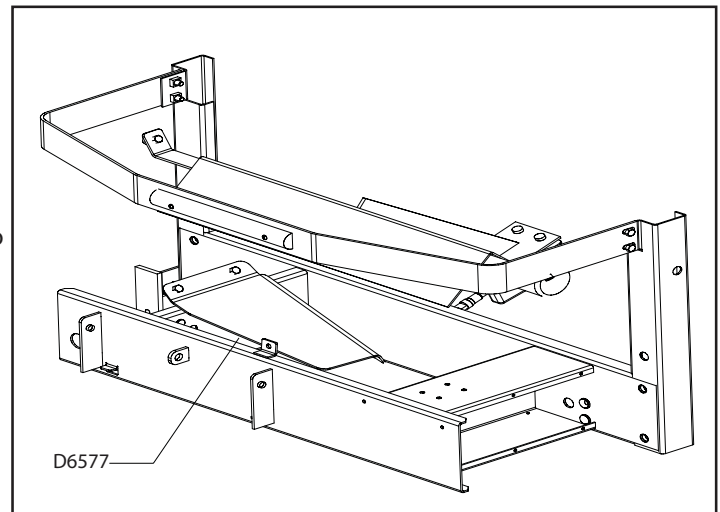

WARNING PROTECTION

- If audible beeping occurs, read display to identify problem: if display reads "OL" (overload) or "OH" (overheat), shut controller down and carefully clear jammed auger. If display reads "E1" this means there is a dead short in system. Do not use until problem is corrected. If display reads "E0", this means that the motor is not getting any power. Check all connections. If display reads "LB" the vehicle battery is extremely low and could damage the system. Also check for poor connections which also can cause the same error code.
- If there are any problems while operating the spreader, refer to Troubleshooting Guide.

AUTO-REVERSE "AR" FUNCTION

- If your controller displays "OL" this could indicate a jammed auger.
- To engage the Auto-Reverse "AR" function:

Step 1: Shut the Main Power Switch OFF for 3 seconds.

Step 2: Turn the Main Power Switch ON. When the machine starts back up the "AR" sequence will automatically start and the auger will reverse for several rotations to clear the jam.

- After a pause of several moments, the auger will automatically return to correct rotation.
- If the jam is still not cleared, the controller will again display "OL".
- You may repeat Steps 1 & 2 for a second and third time.
- If after the third try the controller displays "OL" — you must extract the material that is causing the problem.
- Follow all warning directions when clearing jams.

Troubleshooting



Model # SP-3000/SP-6000

Whenever service is necessary, your local SnowEx Dealer knows your Spreader best. Take your Spreader to your local dealer for any maintenance or service needs on your unit. If this is not possible, the Troubleshooting Guide below may assist you in identifying the problem.

Warning: First read all warning instructions and safety messages before servicing your spreader.

Preliminary Checks

- Be sure all electrical connections are tight and clean.
- Be sure nothing is jammed in the hopper.

PROBLEM	POSSIBLE CAUSE	SOLUTION
Motor doesn't run.	Loose electrical connections.	Check all connections.
	Blown Fuse.	Replace fuse.
	Motor Seized.	Replace motor.
Controller shut down.	Jammed auger.	Carefully clear jammed material.
	Poor electrical connections.	Clean or replace connectors. Use dielectric grease.
	Electrical short.	Check electrical connections. Check for bare wires.
	Controller failure.	Replace controller.
Material not flowing from hopper.	Empty hopper.	Fill hopper.
	Wet material.	Replace with dry material.
	Frozen or coarse material.	Replace material.
	Spinner not turning.	Check drive assembly.
	Auger loose on shaft.	Tighten locking bolt on the side of the auger. There is a flat machined on the driver shaft. Align the auger with this flat and tighten the bolt.
	Vibrator not working.	Replace vibrator
Audible alarm beeping and display shows OL or OH.	Jammed auger, overload shut down.	Turn off for three seconds, then restart. If shut down continues, turn off controller. Clear debris and lumps from auger areas.
Audible alarm beeping display shows E1.	Short in system.	Turn off. Do not use until problem is corrected.
Audible alarm beeping display shows EO.	Motor is not getting power.	Turn off. Check all connections.
Audible alarm beeping display shows LB.	Vehicle battery is extremely low, or a poor connection exists.	Turn off. Charge battery.

Troubleshooting

Model # SP-3000/SP-6000

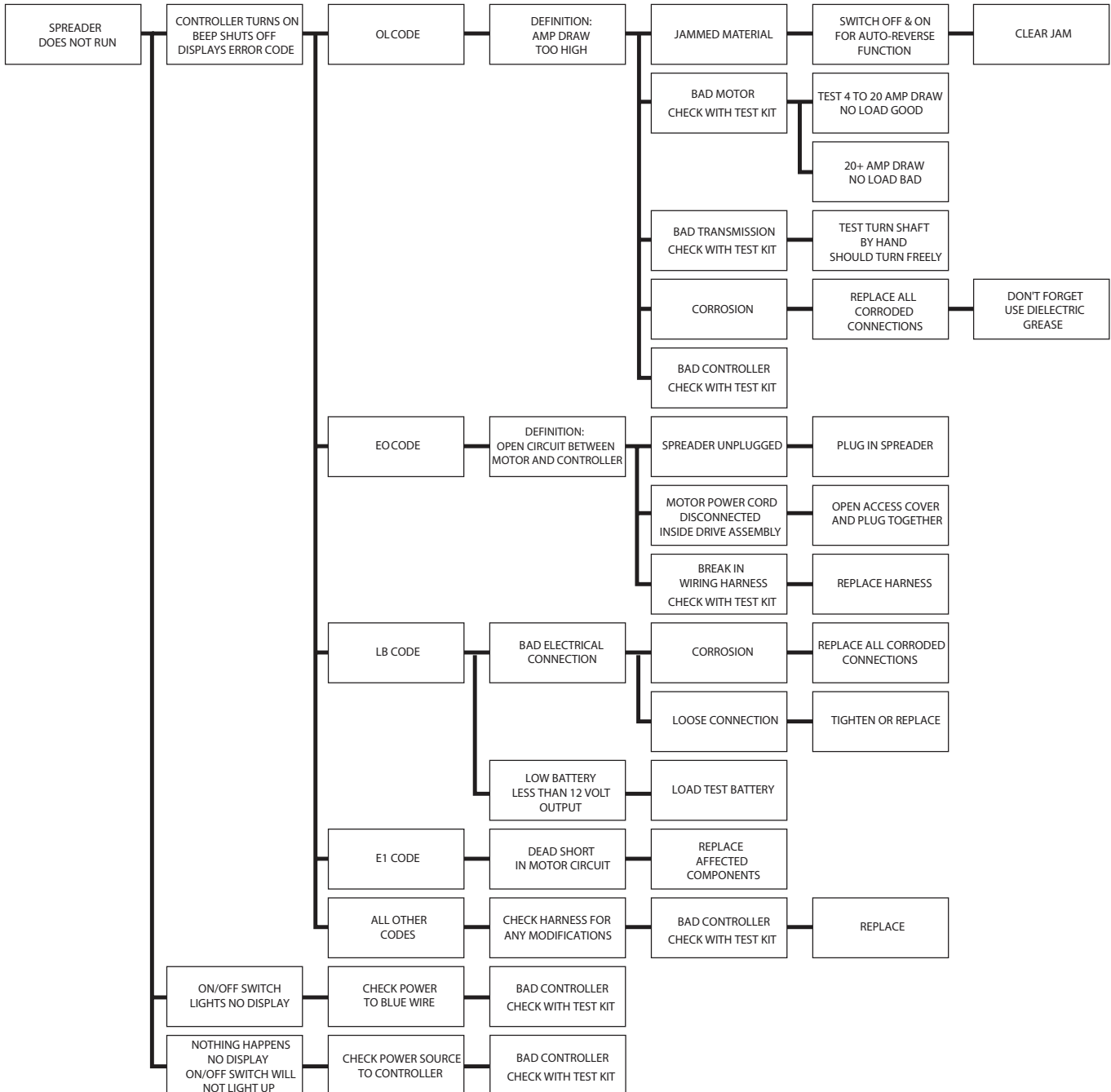

SNOWEX DIAGNOSTIC TEST KIT (STK-020) IS AVAILABLE TO ACCURATELY DIAGNOSE ANY ISSUES WITH SNOWEX SPREADERS. CALL YOUR DEALER FOR DETAILS.

Troubleshooting Material Flow

Model # SP-3000/SP-6000

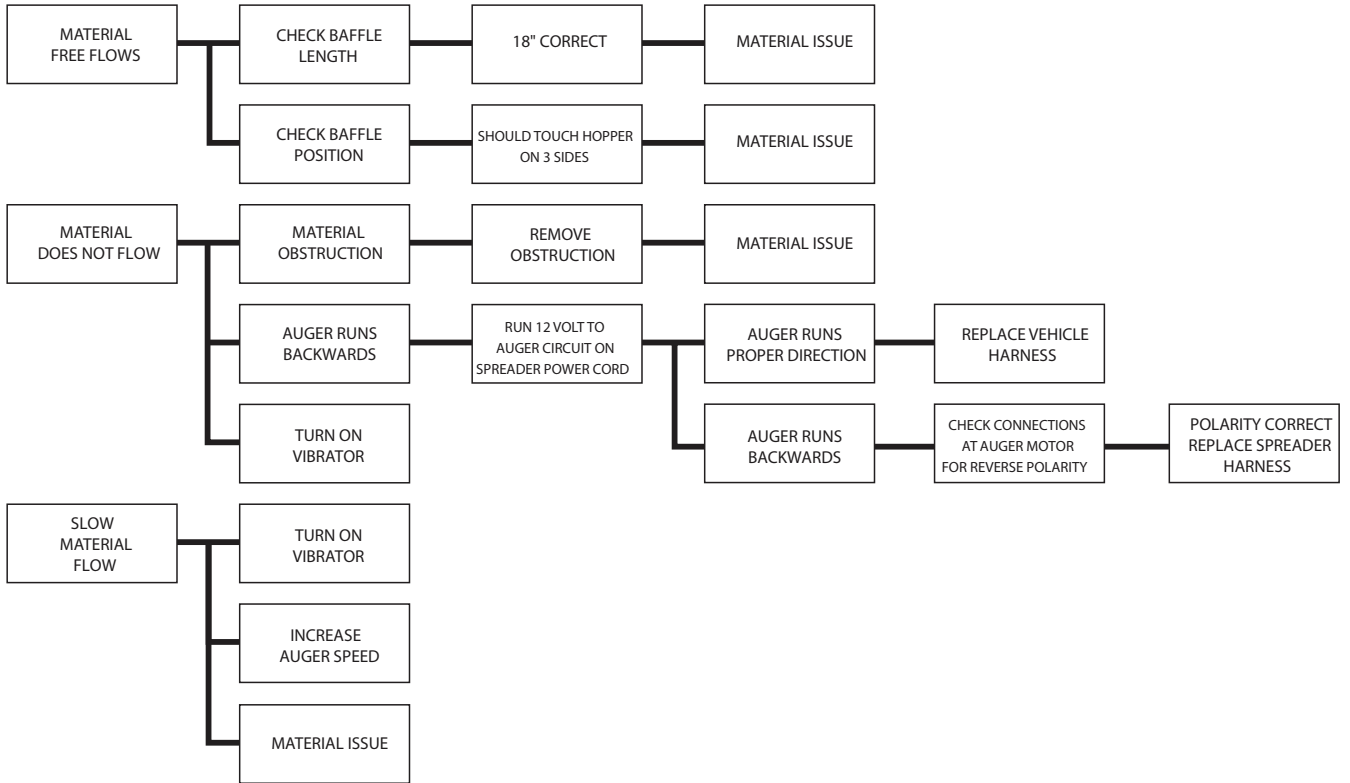

* Spreader capable of spreading most granular bulk material, including coarse 50/50 salt/sand mix with Optimum Flow Kit.

NOTE: Optional Optimum Flow Kit Available, To Increase Material Flow

SNOWEX DIAGNOSTIC TEST KIT (STK-020) IS AVAILABLE TO ACCURATELY DIAGNOSE ANY ISSUES WITH SNOWEX SPREADERS. CALL YOUR DEALER FOR DETAILS.

Spreader Maintenance



Model # SP-3000/SP-6000

- **WARNING** – When servicing is necessary, perform it in a protected area. Do not use power tools in rain or snow because of danger of electrical shock or injury. Keep area well lighted. Use proper tools. Keep the area of service clean to help avoid accidents.
- **WARNING** – Disconnect electricity to spreader before servicing.
- **CAUTION** – The controller is a solid state electronic unit and is not serviceable. Any attempt to service will void warranty.
- **CAUTION** – There are no serviceable parts in the motor/transmission assembly. Any attempt to service will void warranty.
- **CAUTION** – When replacing parts use only original manufacturer's parts. Failure to do so will void warranty.
- Use dielectric grease on all electrical connections to prevent corrosion at the beginning and end of the season and each time plugs are disconnected.
- Gently wash unit after each use to prevent material build-up and corrosion.
- **CAUTION** – When pressure washing motor enclosure area stay at least 36" away from all electrical items.
- Paint or oil all bare metal surfaces at the end of the season.
- Apply small amount of light oil to latches as needed.
- If motor cover is removed for any reason, use silicone sealant to ensure weather proofing of enclosure.
- Grease bearings after every 20 hours' use.
- After first use, tighten all nuts and bolts on spreader and mount.
- **WARNING:** Never remove spreader with material in hopper.
- **ATTENTION:** Store control in cool dry place during the off season.
- **CAUTION** – Spinner motor is not designed for continuous duty. Allow motor to cool between long cycle times.

Useful Formulas



Model # SP-3000/SP-6000

Determining Vehicle Payload

Material Type	Example: Coarse Salt – Dry				
Equipment installed when vehicle was weighed	SP-3000/SP-6000				
Front Gross Axle Weight Rating (RGAWR)					
Rear Vehicle Weight Rating (GVWR) (lb.)	8600				
Gross Vehicle Weight (GVW) (lb.) (empty)	– 6500	–	–	–	–
Payload Available (lb.)	= 2100	=	=	=	=
Material Weight (lb./cu. yd.)	÷ 1431	÷	÷	÷	÷
Maximum Volume (cu. yd.)	= 1.47	=	=	=	=
Maximum Height (approximate) (in.)	24"				
Loaded Front Gross Axle Weight (FGAW) (lb.)					
Loaded Rear Gross Axle Weight (RGAW) (lb.)					
Loaded Gross Vehicle Weight (GVW) (lb.)					

Torque Chart

When tightening fasteners, refer to the Torque Chart below for the recommended fastener torque values.

SIZE	SAE Grade 2	SAE Grade 5	SAE Grade 8
1/4-20	6	9	13
5/16-18	11	18	28
3/8-16	19	31	46
3/8-24	24	46	68
7/16-14	30	50	75
1/2-13	45	75	115
9/16-12	66	110	165
5/8-11	93	150	225
3/4-10	150	250	370
7/8-9	202	378	591
1-8	300	583	893

SIZE	TORQUE	SIZE	TORQUE
M 6	7	M 12	60
M 8	17	M 14	95
M 10	35	M 16	155

These torque values apply to mount assembly fasteners except those noted in the instruction.

Material Weights

Refer to the table below for the weight per cubic yard of common spreading materials.

MATERIAL	WEIGHT (lb. per cubic yard)
Fine Salt – Dry	2,025
Coarse Salt – Dry	1,431
Sand/Salt Mix – Dry (50/50)	2,700
Cinders	1,080

THIS PAGE INTENTIONALLY LEFT BLANK

THIS PAGE INTENTIONALLY LEFT BLANK

THIS PAGE INTENTIONALLY LEFT BLANK

Limited Warranty

Snowex products are warranted for a period of two years from the date of purchase against defects in material or workmanship under normal use and service, subject to limitations detailed below. Warranty period of two years begins on the date of purchase by the original retail user.

The WARRANTY REGISTRATION CARD must be returned to the manufacturer for this warranty to become effective. This warranty applies to the original retail purchaser only. This warranty does not cover damages caused by improper installation, misuse, lack of proper maintenance, alterations or repairs made by anyone other than authorized Snowex dealers or Snowex personnel. Due to the corrosive properties of the materials dispensed by spreaders, Trynex does not warrant against damage caused by corrosion. Warranty claims by the user must be made to the dealer from where the product was purchased, unless otherwise authorized by Snowex. Snowex reserves the right to determine if any part is defective and to repair or replace such parts as it elects. This warranty does not cover shipping costs of defective parts to or from the dealer.

LIMITATION OF LIABILITY

Neither Snowex, nor any company affiliated with it, makes any warranties, representations for promise as to the performance or quality other than what is herein contained. The liability of Snowex to the purchaser for damages arising out of the manufacture, sale, delivery, use or resale of this spreader shall be limited to and shall not exceed the costs of repair or replacement of defective parts. Snowex shall not be liable for loss of use, inconvenience or any other incidental, indirect or consequential damages, so the above limitations on incidental or consequential damages may not apply to you.

NO DEALER HAS AUTHORITY TO MAKE ANY REPRESENTATION OR PROMISE ON BEHALF OF SNOWEX, OR TO ALTER OR MODIFY THE TERMS OR LIMITATIONS OF THIS WARRANTY IN ANY WAY.

Warranty Registration and Customer Survey



To initiate the warranty on your new SnowEx spreader and assure prompt warranty service, please complete the following warranty registration and customer survey, sign and mail it back to the factory within 30 days of purchase.

- 1) Date of Purchase: _____
 - 2) Name: _____
Address: _____

Phone: _____
 - 3) SnowEx Model Purchased: _____ Serial Number: _____
 - 4) Is this your first Trynex Spreader? Yes No
 - 5) What type of vehicle are you using with your Spreader?
Make _____ Model _____ Year _____
 - 6) What type of material are you using in your spreader? _____
 - 7) SnowEx Dealer Name: _____
SnowEx Dealer Address: _____

SnowEx Dealer Phone: _____
 - 8) Does your Trynex Dealer stock Trynex replacement Parts? Yes No I don't know
 - 9) Do you feel your Trynex Dealer sold you the correct product for your needs/application? Yes No
 - 10) How would you rate your overall satisfaction with your SnowEx Dealer?

<input type="checkbox"/>	<input type="checkbox"/>	<input type="checkbox"/>	<input type="checkbox"/>	<input type="checkbox"/>	<input type="checkbox"/>
Very Satisfied	Satisfied	Somewhat Satisfied	Somewhat Dissatisfied	Dissatisfied	Very Dissatisfied
 - 11) How would you rate your overall satisfaction with your SnowEx Product?

<input type="checkbox"/>	<input type="checkbox"/>	<input type="checkbox"/>	<input type="checkbox"/>	<input type="checkbox"/>	<input type="checkbox"/>
Very Satisfied	Satisfied	Somewhat Satisfied	Somewhat Dissatisfied	Dissatisfied	Very Dissatisfied
 - 12) Would you purchase another Trynex Product? Yes No
 - 13) If you would like to receive **E-Mail ALERTS** for new products, bulletins or special promotions please supply address: _____
 - 14) Please use the space below to convey your comments and/or suggestions.

- NOTE: I have read the owner's manual and all safety precautions and I understand that this equipment could be dangerous if not operated with care and under the proper conditions.

15) Owner's signature: **X** _____

PLEASE FOLD AND SEAL WITH TRANSPARENT TAPE BEFORE MAILING.